



# Operating Manual

Version 1.1.6

**Lathe** (L691)

**OPTI**turn<sup>®</sup>  
TU 3008G

Part no. 3427210

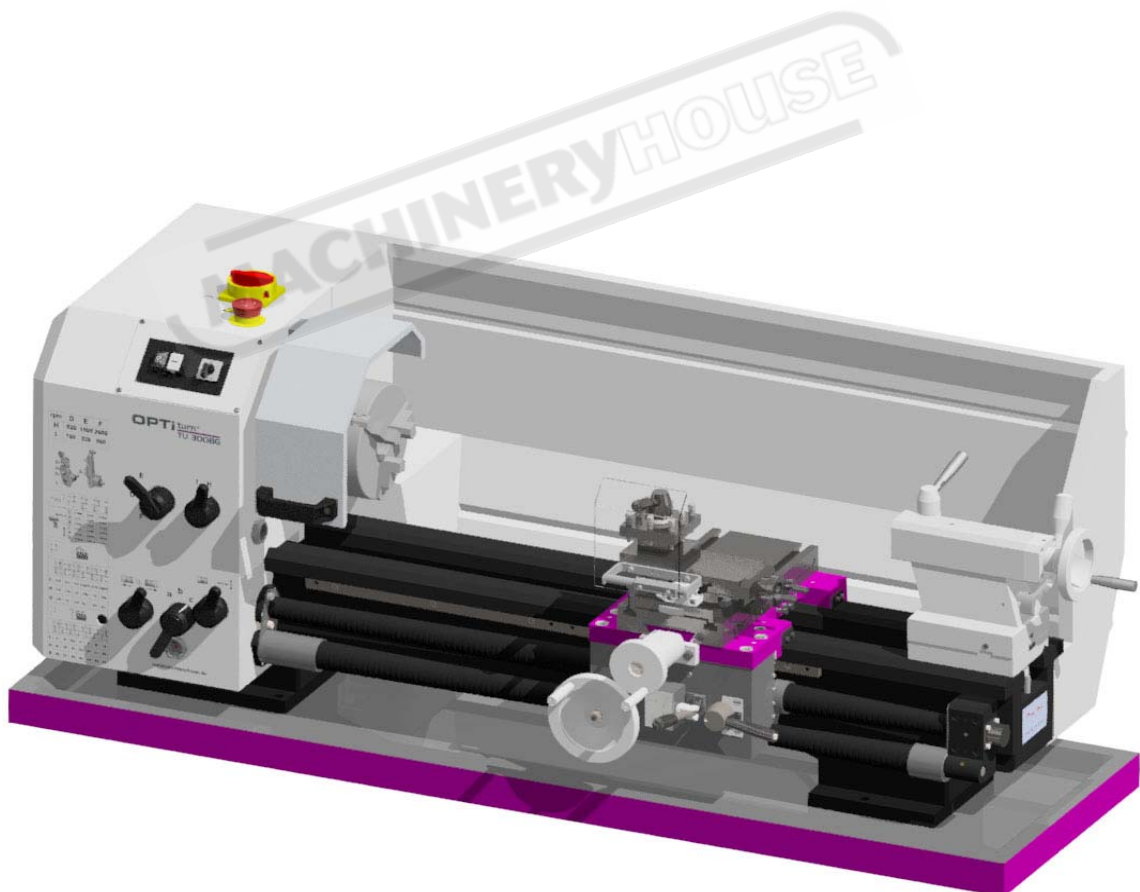



## Table of contents

<b>1</b>	<b>Safety</b>	
1.1	Rating plate.....	6
1.2	Safety instructions (warning notes).....	7
1.2.1	Classification of hazards .....	7
1.2.2	Pictograms .....	7
1.3	Intended use .....	8
1.4	Reasonably foreseeable misuses.....	9
1.4.1	Avoiding misuse.....	9
1.5	Potential dangers that can be caused by the lathe.....	9
1.6	Qualification .....	10
1.6.1	Target group private users .....	10
1.6.2	Obligations of the User.....	10
1.6.3	Additional requirements regarding the qualification .....	10
1.7	User positions .....	10
1.8	Safety measures during operation.....	11
1.9	Safety devices .....	11
1.9.1	Emergency-stop switch .....	12
1.9.2	Protective cover of the headstock.....	12
1.9.3	Lathe chuck protection with position switch .....	13
1.9.4	Protective cover lead screw and feed rod .....	13
1.10	Safety check .....	13
1.11	Personal protective equipment .....	14
1.12	Safety during operation.....	14
1.12.1	Disconnecting and securing the lathe .....	15
1.12.2	Using lifting equipment.....	15
1.12.3	Mechanical maintenance work.....	15
1.13	Electronics .....	15
<b>2</b>	<b>Technical specification</b>	
2.1	Electrical connection.....	16
2.2	Drive motor power .....	16
2.3	Work areas .....	16
2.4	Headstock.....	16
2.5	Feeds and pitches .....	16
2.6	Slides.....	17
2.7	Tailstock.....	17
2.8	Machine dimensions .....	17
2.9	Work area .....	17
2.10	Environmental conditions.....	17
2.11	Operating material .....	17
2.12	Emissions .....	17
<b>3</b>	<b>Delivery, interdepartmental transport and unpacking</b>	
3.1	Notes on transport, installation and unpacking.....	18
3.1.1	General risks during internal transport.....	18
3.2	Delivery.....	19
3.2.1	Load suspension point .....	19
3.2.2	Lifting with lifting equipment.....	20
3.2.3	Lifting with a forklift.....	20
3.3	Machine Center of Gravity .....	21
3.3.1	without a machine base .....	21
3.3.2	with an optional machine base.....	22
3.4	Installation conditions .....	22
3.5	Cleaning the machine .....	23
3.5.1	Lubrication.....	23
3.6	First commissioning .....	23
3.7	Electrical connection.....	24
3.8	Warming up the machine.....	24
<b>4</b>	<b>Operation</b>	
4.1	Control and indicating elements .....	25



4.2	Safety .....	26
4.2.1	Overview of the control elements .....	26
4.2.2	Overview of indicator elements .....	27
4.2.3	Control elements .....	28
4.3	Switching on the machine .....	28
4.3.1	Switching on .....	28
4.4	Switching the machine off .....	29
4.5	Resetting an emergency stop condition .....	29
4.6	Resetting the motor circuit breaker .....	29
4.7	Power failure, Restoring readiness for operation .....	29
4.8	Speed setting .....	30
4.9	Fixing the lathe saddle .....	30
4.10	Changing the feed rate .....	30
4.10.1	Selector switch .....	30
4.10.2	Changing the change gears .....	31
4.10.3	Feed table, table for thread cutting .....	33
4.11	Cross feed, longitudinal feed engagement lever .....	33
4.12	Tool holder .....	34
4.13	Lathe spindle fixture .....	34
4.13.1	Adjusting the Camlock bolts to the workpiece holder .....	35
4.13.2	Replacing the clamping jaws on the lathe chuck .....	36
4.13.3	Clamping a workpiece into the three jaw chuck .....	37
4.14	Taper turning .....	37
4.14.1	Taper turning with the top slide .....	37
4.14.2	Taper turning with the tailstock .....	38
4.14.3	Turning of cones with high precision .....	38
4.15	Standard values for cutting data when turning .....	41
4.16	Cutting speed table .....	41
4.17	Terms for the rotating tool .....	42
4.17.1	Cutting edge geometry for turning tools .....	43
4.17.2	Types of cutting form levels .....	43
4.18	Tapping of external and internal threads .....	45
4.19	Thread types .....	46
4.19.1	Metric threads (60° flank angle) .....	47
4.19.2	British thread (55° flank angle) .....	49
4.19.3	Indexable inserts .....	50
4.19.4	Examples for thread cutting .....	51
4.20	General operating instructions .....	53
4.20.1	Clamping long workpieces .....	53
4.21	Mounting of rests .....	53
4.22	Tailstock .....	54
4.22.1	Cross-adjustment of the tailstock .....	55
4.23	General operating instructions .....	56
4.23.1	Longitudinal turning .....	56
4.23.2	Face turning and recessing .....	56
4.23.3	Turning short tapers with the top slide .....	56
4.23.4	Thread cutting .....	57
4.24	Cooling lubricant .....	58
4.25	Rotary chuck - K11-160 ISO 702-2 .....	59
4.25.1	Safety instructions .....	60
4.25.2	Basic safety instructions .....	61
4.25.3	Optional soft lathe chuck jaws .....	61
4.25.4	Calculating the required clamping force for a given speed .....	62
4.25.5	Clamping force-speed diagram - Lathe chuck K11-160 .....	63
4.25.6	Clamping jaw centrifugal force .....	63
4.25.7	Notes on instruction of operating personnel .....	65
4.25.8	Lubricating and cleaning the lathe chuck .....	66
<b>5</b>	<b>Maintenance</b> .....	
5.1	Safety .....	67
5.1.1	Preparation .....	67
5.1.2	Restarting .....	67
5.1.3	Cleaning .....	68



5.2	Check up, inspection and maintenance .....	68
5.3	Repair .....	74
5.3.1	Customer service technician .....	74
<b>6</b>	<b>Ersatzteile - Spare parts</b>	
6.1	Ersatzteilbestellung - Ordering spare parts .....	75
6.2	Hotline Ersatzteile - Spare parts Hotline .....	75
6.3	Service Hotline .....	75
6.4	Ersatzteilzeichnungen - Spare part drawings .....	76
6.5	Schaltplan - Wiring diagram .....	99
<b>7</b>	<b>Malfunctions</b>	
<b>8</b>	<b>Appendix</b>	
8.1	Copyright .....	106
8.2	Terminology/Glossary .....	106
8.3	Liability claims/warranty .....	107
8.4	Storage .....	108
8.5	Dismantling, disassembling, packing and loading .....	108
8.5.1	Decommissioning .....	109
8.5.2	Dismantling .....	109
8.5.3	Disassembly .....	109
8.5.4	Packing and loading .....	109
8.6	Disposal of new device packaging .....	109
8.7	Disposal of lubricants and cooling lubricants .....	109
8.8	Disposal via municipal collection facilities .....	110
8.9	Product follow-up .....	110
8.10	Change information manual .....	110
<b>9</b>	<b>Genauigkeitsbericht - Accuracy report</b>	

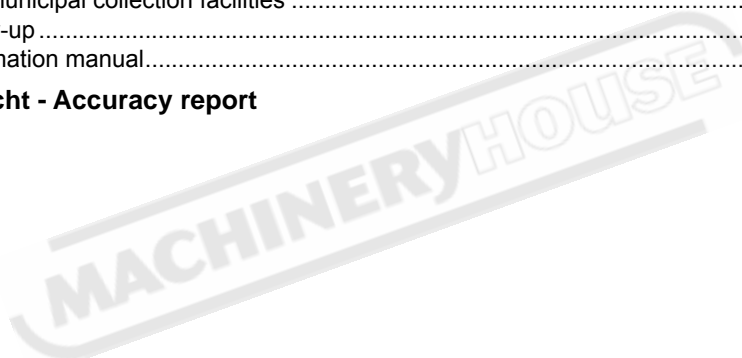



## Preface

Dear customer,

Thank you very much for purchasing a product made by OPTIMUM.

OPTIMUM metal working machines offer a maximum of quality, technically optimum solutions and convince by an outstanding price performance ratio. Continuous enhancements and product innovations guarantee state-of-the-art products and safety at any time.

Before commissioning the machine please thoroughly read these operating instructions and get familiar with the machine. Please also make sure that all persons operating the machine have read and understood the operating instructions beforehand.

Keep these operating instructions in a safe place nearby the machine.

### Information

The operating instructions include indications for safety-relevant and proper installation, operation and maintenance of the machine. The continuous observance of all notes included in this manual guarantee the safety of persons and of the machine.

The manual determines the intended use of the machine and includes all necessary information for its economic operation as well as its long service life.

In the paragraph "Maintenance" all maintenance works and functional tests are described which the operator must perform in regular intervals.

The illustration and information included in the present manual can possibly deviate from the current state of construction of your machine. Being the manufacturer we are continuously seeking for improvements and renewal of the products. Therefore, changes might be performed without prior notice. The illustrations of the machine may be different from the illustrations in these instructions with regard to a few details. However, this does not have any influence on the operability of the machine.

Therefore, no claims may be derived from the indications and descriptions. Changes and errors are reserved!

Your suggestion with regard to these operating instructions are an important contribution to optimising our work which we offer to our customers. For any questions or suggestions for improvement, please do not hesitate to contact our service department.

**If you have any further questions after reading these operating instructions and you are not able to solve your problem with a help of these operating instructions, please contact your specialised dealer or directly the company OPTIMUM.**

Hare & Forbes Machineryhouse

Unit 1,2 Windsor Road

Northmead NSW 2152

Mail: [sales@machineryhouse.com.au](mailto:sales@machineryhouse.com.au)

Internet: [www.machineryhouse.com.au](http://www.machineryhouse.com.au)  
[www.machineryhouse.co.nz](http://www.machineryhouse.co.nz)



## 1 Safety

### Glossary of symbols

	provides further instructions
	calls on you to act
	listings

This part of the operating instructions

- explains the meaning and use of the warning notes included in these operating instructions,
- defines the intended use of the lathe,
- defines the target group of the lathe,
- points out the dangers that might arise for you or others if these instructions are not observed,
- informs you about how to avoid dangers.

In addition to these operation instructions, please observe

- the applicable laws and regulations,
- the statutory provisions for accident prevention,
- the prohibition, warning and mandatory signs as well as the warning notes on the lathe.

European standards must be observed during the installation, operation, maintenance and repair of the lathe.

If European standards have not yet been incorporated in the national legislation of the country of destination, the specific applicable regulations of each country must be observed.

If applicable, necessary measures must be taken to comply with the country-specific regulations before commissioning the lathe.

**Always keep this documentation close to the lathe.**

If you would like to order another operating manual for your machine, please indicate the serial number of your machine. The serial number is located on the type plate.

### 1.1 Rating plate

<ul style="list-style-type: none"> <li>DE Drehmaschine</li> <li>GB Lathe</li> <li>ES Torno</li> <li>FR Tour</li> <li>CZ Soustruh</li> <li>DK Drehbænk</li> <li>FI Kärkisorvi</li> <li>GR Τόρνος</li> <li>HU Esztergápad</li> <li>IT Tornio</li> <li>NL Draaibank</li> <li>PL Tokarka</li> <li>PT Torno</li> <li>RO Strung</li> <li>SE Bänksvarv</li> <li>SK Sústruh</li> <li>TR Torna Tezgahı</li> </ul>	<p><b>OPTIMUM</b> MASCHINEN - GERMANY</p> <p><b>TU 3008G</b></p> <p>NO. 3427210</p> <p>II kW 400 V ~50 Hz</p> <p>260 kg</p> <p>TYP 1 (DIN EN 23125) ≤ 2000 mm ≤ ∅ 500 mm</p> <p>www.optimum-maschinen.de</p>	<p>Optimum Maschinen Germany GmbH Dr.-Robert-Pfleger-Str. 26 D-96103 Hallstadt</p> <p>2600 U/min</p> <p>SN 20</p> <p>Year 20</p>	
--	--	--	--

### INFORMATION

If you are unable to rectify an issue using these operating instructions, please contact us for advice:

Hare & Forbes Machineryhouse

Unit 1,2 Windsor Road

Northmead NSW 2152

Email: [sales@machineryhouse.com.au](mailto:sales@machineryhouse.com.au)



TU3008G\_GB\_1.fm



## 1.2 Safety instructions (warning notes)

### 1.2.1 Classification of hazards

We classify the safety warnings into different categories. The table below gives an overview of the classification of symbols (ideogram) and the warning signs for each specific danger and its (possible) consequences.

Symbol	Signal word	Definition / consequence
	<b>DANGER!</b>	Impending danger that will cause serious injury or death to people.
	<b>WARNING!</b>	A danger that can cause serious injury or death.
	<b>CAUTION!</b>	A danger or unsafe procedure that can cause personal injury or damage to property.
	<b>ATTENTION!</b>	Situation that could cause damage to the lathe and the product and other types of damage. No risk of injury to persons.
	<b>INFORMATION</b>	Practical tips and other important or useful information and notes. No dangerous or harmful consequences for people or objects.

In case of specific dangers, we replace the pictogram with



### 1.2.2 Pictograms





Switching on forbidden!



Do not clean with compressed air!



Read the operating instructions before commissioning!



Wear protective glasses!



Wear protective gloves!



Wear safety shoes!



Wear a protective suit!



Use ear protection!



Protect the environment!



Contact address

## 1.3 Intended use

### WARNING!

**Improper use of the lathe will result in**

- will endanger personnel,
- will endanger the lathe and other material property of the operator,
- the correct function of the lathe may be affected.



The lathe is designed and manufactured to be used in environments where there is no potential danger of explosion.

The lathe is designed and manufactured for longitudinal and straight turning of round and regular formed three-, six- or twelve-square workpieces in cold metal. The lathe must only be installed and operated in a dry and ventilated place.

If the lathe is used in any way other than described above, or modified without the approval of Maschinen Germany GmbH, then the lathe is being used improperly.

We will not be held liable for any damages resulting from any operation which is not in accordance with the intended use.

We expressly point out that the guarantee or CE conformity will expire, if any constructive, technical or procedural changes are not performed by the company Optimum Maschinen Germany GmbH.

It is also part of the intended use that you

- observe the limits of the lathe,
- observe the operating instructions,
- and comply with the inspection and maintenance instructions.

📖 Technical specification on page 16

In order to achieve optimum cutting performance, it is essential to choose the right turning tool, feed, tool pressure, cutting speed and coolant.

### WARNING!

**Extremely severe injuries due to non-intended use.**

**It is forbidden to make any modifications or alternations to the operation values of the lathe. They could endanger the personnel and cause damage to the lathe.**



TU3008G\_GB\_1.fm





## 1.4 Reasonably foreseeable misuses

Any other use other than that specified under "Intended use" or any use beyond the described use shall be deemed as non-intended use and is not permissible.

Any other use has to be discussed with the manufacturer.

The lathe must not be used to process metal, cold and non-inflammable materials.

In order to avoid misuse, it is necessary to read and understand the operating instructions before the first commissioning.

The lathe operator must be qualified. ⓘ Target group private users on page 10

### 1.4.1 Avoiding misuse

- Use of suitable cutting tools.
- Adapting the speed adjustment and feed to the material and workpiece.
- Insert the workpiece tightly, without vibration and without one-sided imbalances.
- The machine is not designed for the use of hand tools (e.g. emery cloth or files). It is forbidden to use any hand tools on this machine.
- The machine is not designed to allow long parts to protrude beyond the spindle hole. If longer parts have to protrude beyond the spindle hole, an additional operator-side, permanent device must be mounted, which completely covers the protruding part and provides complete protection against spinning parts.
- Long workpieces must be propped up. Use the steady rest or follow rest in conjunction with the tailstock spindle to support longer parts and prevent the workpiece from flapping around and flying away.
- Risk of fire and explosion due to the use of flammable materials or cooling lubricants. Before processing inflammable materials (e.g. aluminium, magnesium) or using inflammable auxiliary materials (e.g. spirit), it is necessary to take additional preventive measures in order to avoid health risks.
- When processing carbons, graphite and carbon-fibre-reinforced carbons, the machine is no longer being used as intended. When processing carbons, graphite and carbon-fibre-reinforced carbons and similar materials, the machine can be damaged quickly, even if the dusts generated are completely sucked out during the work process.
- The processing of plastics with the lathe leads to static charge. The static charge of machine parts from processing plastics cannot be safely conducted away from the lathe.
- When using lathe dogs as carriers for rotating workpieces between the lathe centres, the standard lathe chuck shield must be replaced with a circular lathe chuck shield.

## 1.5 Potential dangers that can be caused by the lathe

The lathe has been tested for operational safety. The construction and type are state of the art.

Nevertheless, there is a residual risk as the lathe operates with

- high revolutions,
- with rotating parts,
- electrical voltage and currents,

We have used design and safety engineering to minimize the health risk to personnel resulting from these hazards.

If the lathe is used and maintained by personnel who are not duly qualified, there may be a risk resulting from incorrect or unsuitable maintenance of the lathe. ⓘ Target group private users on page 10

### INFORMATION

Everyone involved in the assembly, commissioning, operation and maintenance must

- be duly qualified,





- and strictly follow these operating instructions.

In the event of improper use

- there may be a risk to the persons,
- there is a risk of damage to the lathe and other property,
- the correct function of the lathe may be affected.

Always disconnect the lathe, when cleaning or maintenance work is being carried out.

## WARNING!

**The lathe may only be used with the safety devices activated. Disconnect the lathe immediately whenever you detect a failure in the safety devices or when they are not mounted!**  **Safety devices on page 11**

## 1.6 Qualification

### 1.6.1 Target group private users

The machine can be used in the private domain. The acumen of people in the private sector with training in metal working was taken into consideration for creating this operation manual. Vocational training or further instruction in a metal working profession is a prerequisite for safe operation of the machine. It is essential that the private user is aware of the dangers involved in operating this machine. We recommend visiting a training course in the operation of lathes. Your specialist dealer can offer you an appropriate training course. These courses are also offered by adult education centres in Germany.

### 1.6.2 Obligations of the User

The user must

- have read and understood the operating manual,
- be familiar with all safety devices and regulations,
- be able to operate the lathe.

### 1.6.3 Additional requirements regarding the qualification

Additional requirements apply for work on electrical components or equipment:

- They must only be performed by a qualified electrician or person working under the instructions and supervision of a qualified electrician.

Before starting work on electrical parts or operating agents, the following actions must be taken in the order given:

- ➔ disconnect all poles,
- ➔ secure against restarting,
- ➔ check that there is no voltage.

## 1.7 User positions

The operator position is in front of the lathe.



## 1.8 Safety measures during operation

### CAUTION!

Danger due to inhaling dust and mist that is hazardous to health.

Dependent on the material which need to be processed and the used auxiliaries dusts and mist may be caused which might impair you health.

Make sure that the generated health hazardous dusts and mist are safely sucked off at the point of origin and is dissipated or filtered from the working area. To do so, use a suitable extraction unit.



### CAUTION!

Risk of fire and explosion by using flammable materials or cooling lubricants.

Before processing inflammable materials (e.g. aluminium, magnesium) or using inflammable auxiliary materials (e.g. spirit) it is necessary to take additional preventive measures in order to safely avoid health risks.



### CAUTION!

Risk of becoming entangled or lacerations when using hand tools.

The machine is not designed for the use of hand tools (e.g. emery cloth or files). It is forbidden to use any hand tools on this machine.



Before processing inflammable materials (e.g. aluminium, magnesium) or using inflammable auxiliary materials (e.g. spirit) it is necessary to take additional preventive measures in order to safely avoid health risks.

## 1.9 Safety devices

Use the lathe only with properly functioning safety devices.

Stop the lathe immediately if there is a failure on the safety device or if it is not functioning for any reason.

It is your responsibility!

If a safety device has been deactivated or is defective, the lathe can only be used again if you

- the cause of the fault has been eliminated,
- you have verified that there is no danger to personnel or objects.

### WARNING!

If you bypass, remove or override a safety device in any other way, you are endangering yourself and other persons working on the lathe. The possible consequences are:

- injuries due to components or workpieces flying off at high speed,
- contact with rotating parts and
- fatal electrocution,
- pulling-in of clothes.



The lathe includes the following safety devices:

- an emergency-stop mushroom switch,
- a lathe chuck protection with position switch,
- a protective cover on the headstock with interlock switch,
- a safety screw at the tailstock,
- a coil spring as protective cover on the lead screw and feed rod; the coil spring prevents clothes and body parts from being pulled into the machine.
- an overload clutch on the feed rod,
- a chips shield.



## WARNING!

The protective equipment for material separation that is made available and delivered together with the machine is designed to reduce the risk of workpieces or fractions of them being expelled from the machine, but not to remove them entirely.



### 1.9.1 Emergency-stop switch

#### CAUTION!

**The drive or the lathe chuck will continue to run for a while, depending on the mass moment of inertia of the lathe chuck and the workpiece.**

The emergency stop button brings the machine to a standstill.

Turn the knob to the right to unlock and release the emergency stop button.



#### CAUTION!

**Only press the emergency stop button in a genuine emergency. Do not use the emergency stop button to stop the machine during normal operation.**



Img. 1-1: Emergency-stop switch

### 1.9.2 Protective cover of the headstock

The headstock of the lathe is equipped with a separating protective cover. The protective cover is equipped with an interlock switch and can only be opened when the machine is turned off.



Img. 1-2: Protective cover of the headstock



### 1.9.3 Lathe chuck protection with position switch

The lathe is equipped with a lathe chuck protection. The spindle of the lathe can only be switched on if the lathe chuck protection is closed.



Img. 1-3: Lathe chuck protection

### 1.9.4 Protective cover lead screw and feed rod

The lead screw and the feed rod of the lathe is covered with a coil spring as a protective cover.

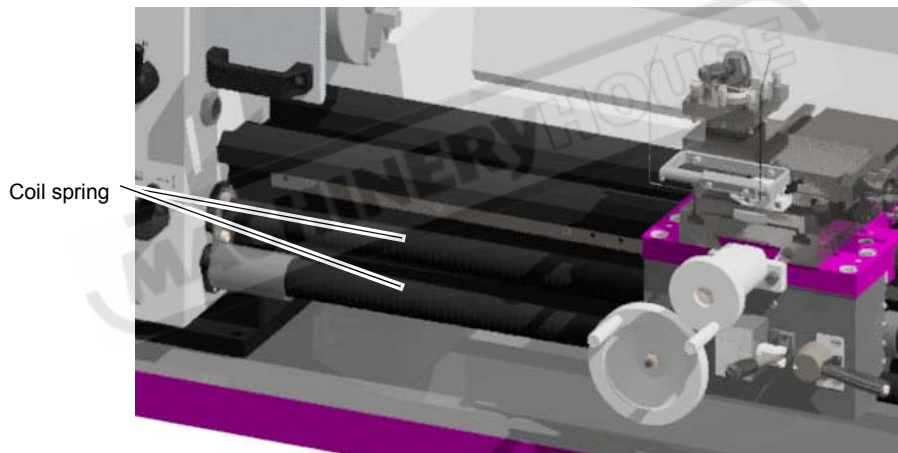

Img. 1-4: Lead screw and feed rod with protective cover

### 1.10 Safety check

Check all safety devices

- when starting any work,
- once a week,
- after all maintenance and repair work.

#### INFORMATION

Use the following summary to perform the checks.



General check		
Equipment	Check	OK
Guards	Mounted, firmly bolted and not damaged	

TU3008G\_GB\_1\_fm



General check		
Equipment	Check	OK
Signs, Markers	Installed and legible	

Functional check		
Equipment	Check	OK
Emergency-stop mushroom switch	After activating the emergency stop mushroom button, the control voltage on the lathe will shut off. The spindle continues to rotate for a while, depending on the mass moment of inertia of the spindle and workpiece.	
Positions switch Lathe chuck protection	The spindle drive of the lathe must only be switch on if the lathe chuck protection is closed.	
Interlock switch protective cover on the headstock	The spindle drive of the lathe must only be switch on if the protective cover of the headstock is closed.	

## 1.11 Personal protective equipment

For certain work personal protective equipment is required.

Protect your face and your eyes: Wear a safety helmet with facial protection when performing work where your face and eyes are exposed to hazards.



Wear protective gloves when handling pieces with sharp edges.



Wear safety shoes when you assemble, disassemble or transport heavy components.



Use ear protection if the noise level (emission) in the workplace exceeds 80 dB (A).

Before starting work make sure that the required personal protective equipment is available at the work place.



### CAUTION!

**Dirty or contaminated personnel protective equipment can cause illness. It must be cleaned after each use and at least once a week.**



## 1.12 Safety during operation

We provide information about the specific dangers when working with and on the lathe in the descriptions for these types of work.

### WARNING!

**Before activating the lathe ensure that this will neither endanger other persons nor cause damage to equipment.**



Avoid any unsafe work methods:

- Make sure that your work does not endanger anyone.
- Clamp the workpiece tightly before activating the lathe.
- Observe the maximum lathe chuck opening.
- Wear safety goggles.
- Do not remove the turning chips by hand. Use a chip hook and / or a hand brush to remove turning chips.



- Clamp the turning tool at the correct height and with the least possible overhang.
- Turn off the lathe before measuring the workpiece.
- The instructions described in these operating instructions must be strictly observed during assembly, operation, maintenance and repair.
- Do not work on the lathe if your concentration is reduced, for example, because you are taking medication.
- Stay at the lathe until all movements have come to a complete standstill.
- Use the prescribed personnel protective equipment. Make sure to wear a well-fitting work suit and, if necessary, a hairnet.

### 1.12.1 Disconnecting and securing the lathe

Pull the power plug before beginning any maintenance or repair work.

All machine parts as well as all dangerous voltages are switched off.

#### WARNING!

**Live parts and moves of machine parts can injure you or others dangerously! If you cannot pull the power plug due to required work (e.g. function check), proceed with extreme caution.**



### 1.12.2 Using lifting equipment

#### WARNING!

**The use of unstable lifting and load suspension equipment that might break under load can cause severe injuries or even death.**

**Check to ensure that the lifting and load-suspension equipment are of sufficient load-bearing capability and are in perfect condition. Fasten the loads properly. Never walk under suspended loads!**



### 1.12.3 Mechanical maintenance work

After your work, reinstall all guards and safety devices dismantled for maintenance work, such as:

- covers,
- safety instructions and warning signs,
- grounding cables.

If you remove protection or safety devices, refit them immediately after completing the work. Check that they are working properly!

## 1.13 Electronics

#### INFORMATION



Have the machine and/or the electric equipment checked regularly. Immediately eliminate all defects such as loose connections, defective wires, etc.



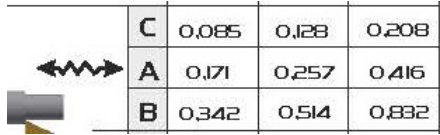

## 2 Technical specification

The following information represents the dimensions and indications of weight and the manufacturer's approved machine data.

<b>2.1 Electrical connection</b>	3x400V ~ 50Hz ( ~ 60 Hz )																					
<b>2.2 Drive motor power</b>	1.1 KW																					
<b>2.3 Work areas</b>																						
Center height [ mm ]	158																					
Distance between centres [ mm ]	720																					
Swing diameter over machine bed [ mm ]	310																					
Swing diameter over cross slide [ mm ]	190																					
Main spindle bore [ mm ]	38																					
Lathe chuck K11-160/D4 bore [ mm]	40																					
<b>2.4 Headstock</b>																						
Main spindle nose	Camlock DIN ISO 702-2 no. 4																					
Main spindle morse taper	MT5																					
Spindle speeds $\pm 5\%$ [ rpm ] when connecting to ~50Hz	165   300   530   750   1400   2400																					
Spindle speeds $\pm 5\%$ [ rpm ] when connecting to ~60Hz	200   360   640   900   1700   2900																					
Speed levels	6 gear stages																					
<b>2.5 Feeds and pitches</b>																						
Longitudinal feed [mm/rev]	 <table border="1"> <tr> <td>C</td> <td>0,085</td> <td>0,128</td> <td>0,208</td> </tr> <tr> <td>A</td> <td>0,171</td> <td>0,257</td> <td>0,416</td> </tr> <tr> <td>B</td> <td>0,342</td> <td>0,514</td> <td>0,832</td> </tr> </table>	C	0,085	0,128	0,208	A	0,171	0,257	0,416	B	0,342	0,514	0,832									
C	0,085	0,128	0,208																			
A	0,171	0,257	0,416																			
B	0,342	0,514	0,832																			
Cross feed [mm/rev]	 <table border="1"> <tr> <td>C</td> <td>0,010</td> <td>0,016</td> <td>0,025</td> </tr> <tr> <td>A</td> <td>0,021</td> <td>0,032</td> <td>0,050</td> </tr> <tr> <td>B</td> <td>0,042</td> <td>0,064</td> <td>0,100</td> </tr> </table>	C	0,010	0,016	0,025	A	0,021	0,032	0,050	B	0,042	0,064	0,100									
C	0,010	0,016	0,025																			
A	0,021	0,032	0,050																			
B	0,042	0,064	0,100																			
Metric thread [mm/rev]	<table border="1"> <tr> <td>0,2</td> <td>0,3</td> <td>0,5</td> <td>0,625</td> <td>0,75</td> <td>0,875</td> </tr> <tr> <td>0,4</td> <td>0,6</td> <td>1,0</td> <td>1,25</td> <td>1,5</td> <td>1,75</td> </tr> <tr> <td>0,8</td> <td>1,2</td> <td>2,0</td> <td>2,5</td> <td>3,0</td> <td>3,5</td> </tr> </table>	0,2	0,3	0,5	0,625	0,75	0,875	0,4	0,6	1,0	1,25	1,5	1,75	0,8	1,2	2,0	2,5	3,0	3,5			
0,2	0,3	0,5	0,625	0,75	0,875																	
0,4	0,6	1,0	1,25	1,5	1,75																	
0,8	1,2	2,0	2,5	3,0	3,5																	
Inch threads [threads/inch]	<table border="1"> <tr> <td>8</td> <td>9</td> <td>9,5</td> <td>10</td> <td>11</td> <td>12</td> <td>14</td> </tr> <tr> <td>16</td> <td>18</td> <td>19</td> <td>20</td> <td>22</td> <td>24</td> <td>28</td> </tr> <tr> <td>32</td> <td>36</td> <td>38</td> <td>40</td> <td>44</td> <td>48</td> <td>56</td> </tr> </table>	8	9	9,5	10	11	12	14	16	18	19	20	22	24	28	32	36	38	40	44	48	56
8	9	9,5	10	11	12	14																
16	18	19	20	22	24	28																
32	36	38	40	44	48	56																

TU3008G\_GB\_2.fm





<b>2.6 Slides</b>	
Travel cross slide [mm]	150
Scale on the handwheel cross slide	4mm/rev - splitting 0.04mm
Travel top slide [mm]	65
Scale on the handwheel top slide	2mm/rev - splitting 0.02mm
Scale on the handwheel lathe saddle	5mm/rev - splitting 0.5mm
maximum dimension for lathe tool in quadruplicate tool holder [mm]	25
<b>2.7 Tailstock</b>	
Quill diameter [mm]	38
Quill travel [mm]	70
Taper in the quill	MT3
<b>2.8 Machine dimensions</b>	
👉 Machine Center of Gravity on page 21	
Weight [ kg ]	260
<b>2.9 Work area</b>	Keep a work area of at least one metre around the machine free for operation and maintenance.
<b>2.10 Environmental conditions</b>	
Temperature	5 - 35 °C
Relative humidity	25 - 80 %
<b>2.11 Operating material</b>	
Speed gear unit Mobilgear 627 or a comparable oil	1.7 litres
Feed gear Mobilgear 629 or a comparable oil	0.1 to 0.15 litres
Bare steel parts and lubricating nipple,	Acid-free lubricating oil
<b>2.12 Emissions</b>	
Maximum sound pressure level at 1 m distance from the machine and 1.60 m above the ground. according to DIN ISO 8525.	Gear step 2400 rpm; 78 dB(A) Gear step 1500 rpm; 76 dB(A)

### CAUTION!

The machine operator should use hearing protection.

### INFORMATION

This numerical value was measured on a new machine under the operating conditions specified by the manufacturer. The noise behaviour of the machine might change depending on the age and wear of the machine. Furthermore, the noise emission also depends on production engineering factors, e.g. speed, material and clamping conditions.





## 3 Delivery, interdepartmental transport and unpacking

### CAUTION!

**Injuries caused by parts falling over or off a forklift, pallet truck or transport vehicle. Only use means of transport that can carry the total weight and are suitable for it.**



### 3.1 Notes on transport, installation and unpacking

Improper transport of individual devices and minor machines, unsecured devices and minor machines stacked on top of each other or next to each other in packed or already unpacked condition is accident-prone and can cause damage or malfunctions for which we do not grant any liability or guarantee.

Transport the scope of delivery secured against shifting or tilting with a sufficiently dimensioned industrial truck to the installation site.

#### 3.1.1 General risks during internal transport

##### CAUTION: DANGER OF TIPPING!

**The device may be lifted unsecured by a maximum of 2cm.**

**Employees must be outside the danger zone, the reach of loads. Warn employees and, if necessary, advise employees of the hazard.**



Act responsibly during transport and always consider the consequences. Refrain from daring and risky actions.

Gradients and descents (e.g. driveways, ramps and the like) are particularly dangerous. If such passages are unavoidable, special caution is required.

Before starting the transport check the transport route for possible danger points, unevenness and disturbances as well as for sufficient strength and load capacity.

Danger points, unevenness and disturbance points must be inspected before transport. The removal of danger spots, disturbances and unevenness at the time of transport by other employees leads to considerable dangers.

Careful planning of internal transport is therefore essential.



## 3.2 Delivery

### INFORMATION

The machine is pre assembled. It is delivered in a transport box. After the unpacking and the transportation to the installation site it is necessary to mount and assemble the individual components of the machine.



Check the status of the machine immediately upon receipt and claim possible damages at the last carrier also if the packing is not being damaged. In order to ensure claims towards the freight carrier we recommend you to leave the machines, devices and packing material for the time being in the status at which you have determined the damage or to take photos of this status. Please inform us about any other claims within six days after receipt of delivery.

Check if all parts are firmly seated.

### 3.2.1 Load suspension point

#### DANGER!

**Danger of crushing and overturning. The lathe must be installed by several persons.**



Weight [ kg ] 260

- Check the horizontal orientation of the base of the lathe with a spirit level.
- Check that the foundation has sufficient load-bearing capacity and rigidity.
- Anchor the machine base or the optional machine base onto the floor before positioning the machine on it.
- Make sure that a sufficiently stable lifting sling (tape sling) is used that can bear the weight.
- Place the lifting sling around the spindle behind the lathe chuck (2) and then around a rib (4) of the machine bed. Then hook the end of the sling back into the crane hook (5). Push the tailstock as far forward as possible. Pay attention to the load centre of gravity, if necessary adjust the position of the sling in the crane hook (3).
- Raise the lathe only as far as is necessary to carry out the work.

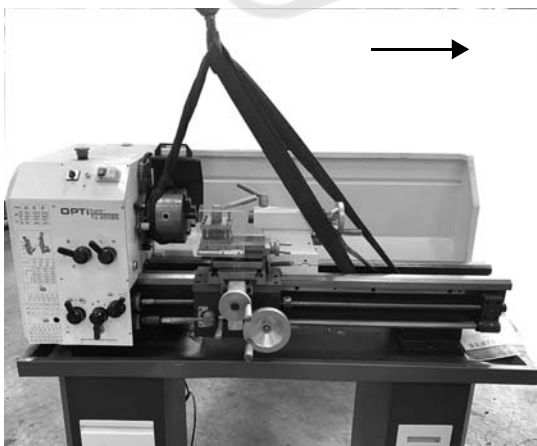

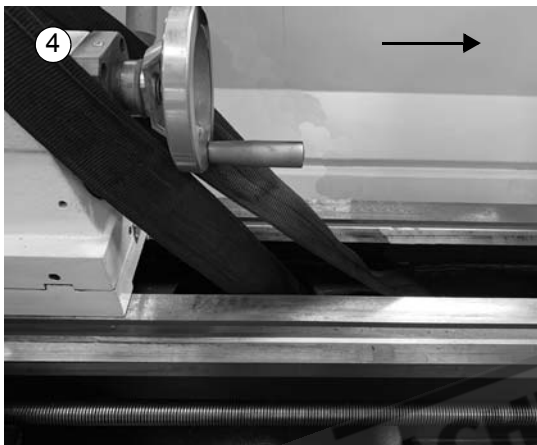
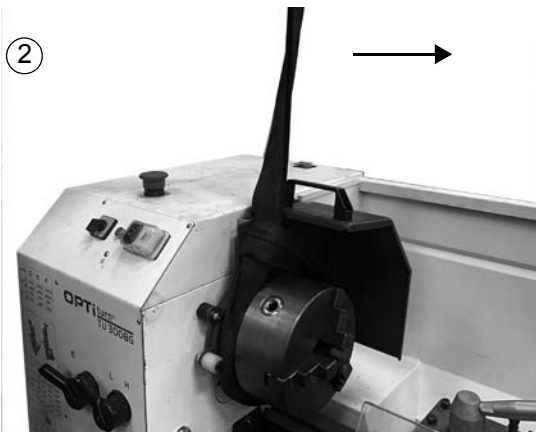

Img.3-1: Load suspension point

### 3.2.2 Lifting with lifting equipment

- Fasten the load suspension gear as presented in  Img.3-1: Load suspension point
- Make sure that you distribute the loads evenly so that the lathe cannot turn over while lifting.
- Make sure that no add-on pieces or varnished parts are damaged due to the load suspension.

### 3.2.3 Lifting with a forklift

It is recommended that the lathe is transported on the lower portion of the packing crate. Disassemble the lateral parts of the packing crate.

Transporting with a forklift:

- Disassemble the splash board on the lathe.
- Lift the lathe with a forklift at the rear side of the machine bed.



### 3.3 Machine Center of Gravity

#### 3.3.1 without a machine base

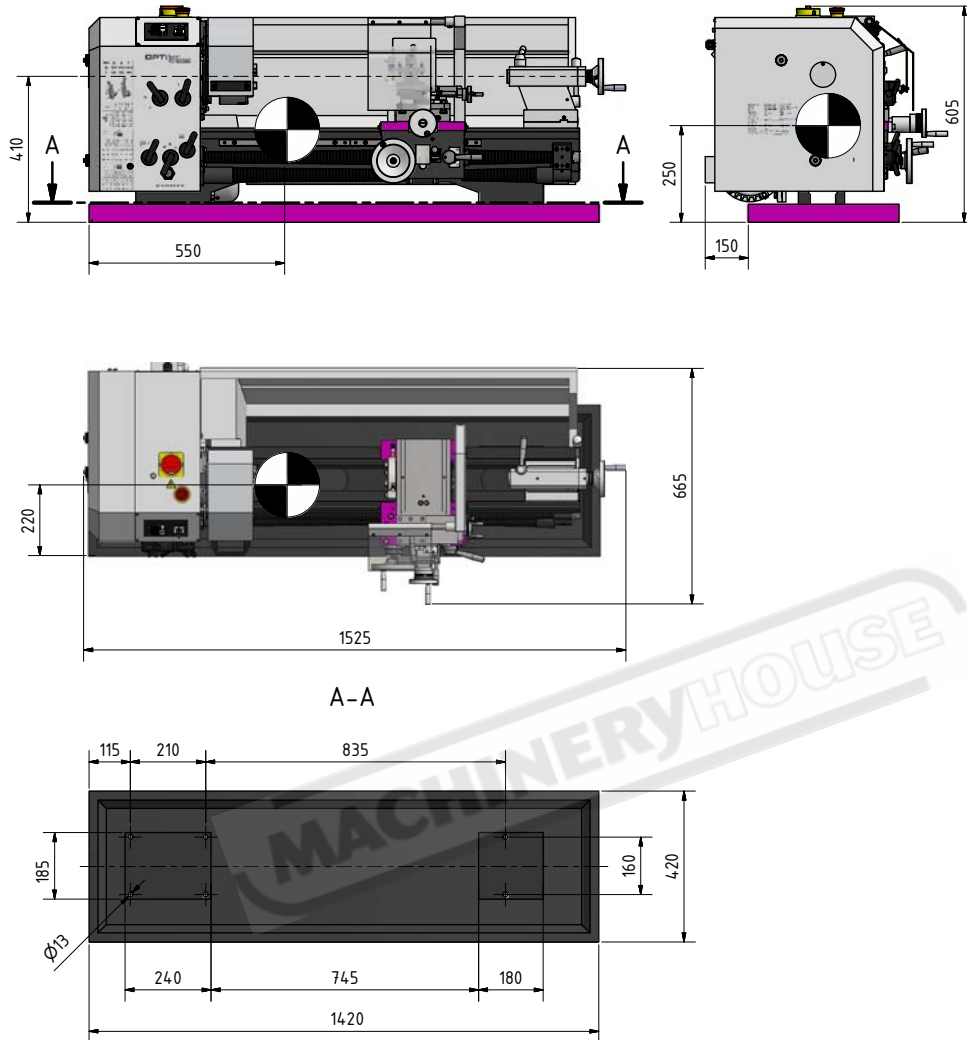

A-A



Schwerpunkt / Centre of gravity



### 3.3.2 with an optional machine base

#### CAUTION!

In order to provide for the necessary stability of the machine with an optional machine base, it is necessary to firmly fasten the machines to the base. The machine base itself must be affixed firmly to the floor.

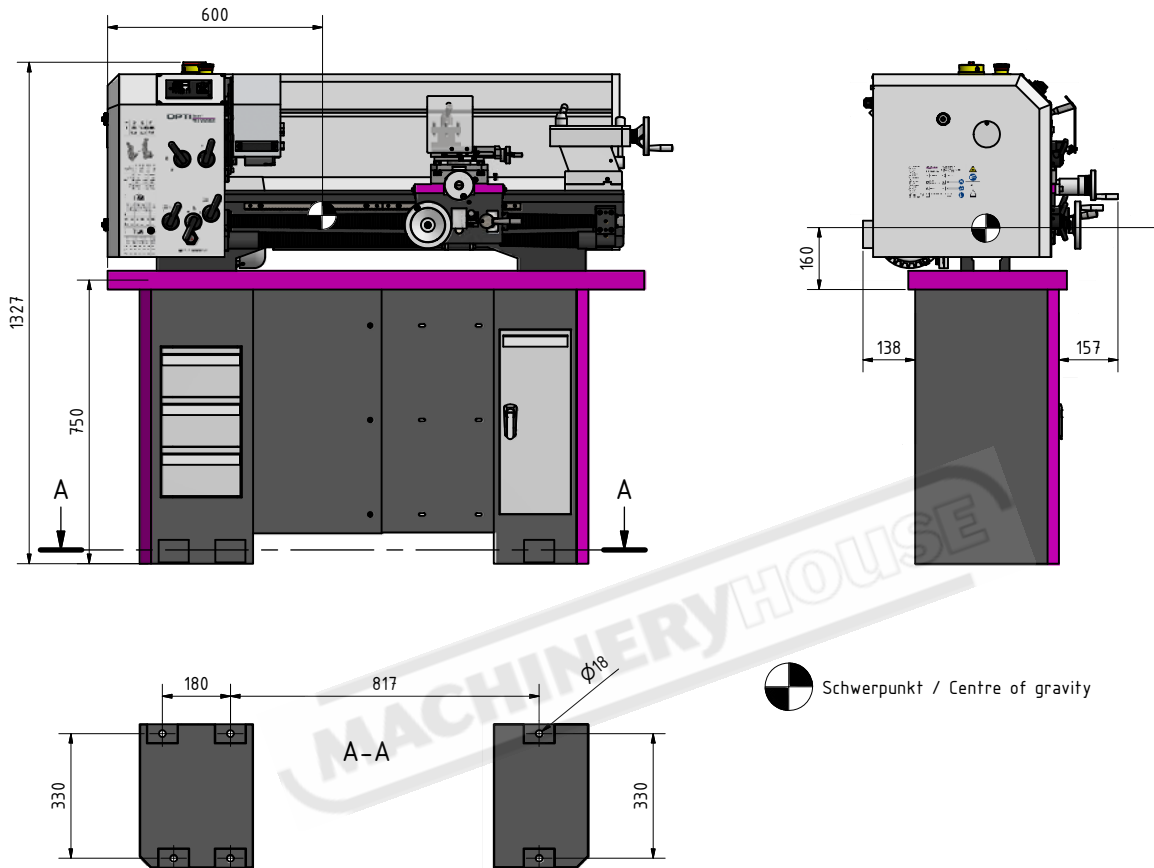

Img.3-2: Example ground fastening

### 3.4 Installation conditions

Organize the working area around the lathe according to the local safety regulations. Work area on page 17

The work area for operation, maintenance and repair must not be restricted.

#### INFORMATION

In order to achieve high levels of functionality and machining accuracy, as well as a long service life of the machine, the set-up location should meet certain criteria.



#### The following points should be noted:

- The machine must only be installed and operated in a dry and well-ventilated place.
- Avoid places near machines generating chips or dust.
- The installation site must be free from vibrations also at a distance of presses, planing machines, etc.
- The ground must be suitable for the lathe. Make sure that the floor has sufficient load-bearing capacity and is level.



- The substructure must be prepared in such a way as to ensure that, if any lubricant is used, it cannot penetrate the floor.
- Protruding parts - such as the dog, handles, etc. - must be secured, where necessary, by means of on-site measures so that persons are not endangered.
- Provide enough space for set-up and operating personnel and material transport.
- Also bear in mind accessibility for installation and maintenance works.
- Ensure adequate lighting is available (minimum value: 500 Lux, measured at the tool tip). In the event of a lower level of lighting, additional illumination must be provided, e.g. by means of a separate workplace light.

## INFORMATION

The power plug of the lathe must be readily accessible.



### 3.5 Cleaning the machine

#### CAUTION!

**Do not use compressed air to clean the machine.**



Your new lathe must be completely cleaned after being unpacked to make sure that all the moving parts and sliding surfaces are not damaged when the machine is operated. Each unit leaves the factory with all its polished parts and sliding surfaces suitably greased to avoid oxidation in the period of time that elapses, until it is started up. Remove all the wrapping and clean all the surfaces with a degreaser to soften and remove the protecting greases and coatings.

Clean all the surfaces with a clean cotton cloth and lubricate the lathe as explained in the following section, before connecting the power and beginning to operate the machine.

#### 3.5.1 Lubrication

When initially lubricating and greasing your new lathe, you can check the oil levels through the viewing pane next to the gears. The oil tank must be filled to the middle of the viewing pane. Only afterwards can the machine be placed into operation.

- ➔ The oil in the gearboxes must be changed 200 hours after being filled for the first time, then annually.
- 🔗 Speed gear unit on page 70
- 🔗 Feed gear on page 71
- ➔ Use the oil types recommended in the reference table 🔗 Lubricant on page 102. This table can be used to compare the characteristics of each different type of oil of your choice.
- ➔ The lubrication nipples must be lubricated every 8 hours using an oiler. Furthermore, it is also recommended to lubricate the slide tracks of the machine bed once a day.

### 3.6 First commissioning

#### WARNING!

**The first commissioning may only take place after proper installation.**

**There is a danger to persons and equipment, if the first commissioning carried out by inexperienced personnel. We do not assume any liability for damages caused by incorrectly performed commissioning.**



#### ATTENTION!

**Before initially operating the machine, check all screws, fixtures and/or safety devices and tighten up the screws if necessary!**





## WARNING!

Risk from using improper workpiece clamping materials or operating the machine at an inadmissible speed.

Only use the tool clamping devices (e.g. lathe chuck) that were delivered with the machine or those offered by OPTIMUM as optional equipment.

Only use tool clamping devices in the intended admissible speed range.



## 3.7 Electrical connection

The machine is installed ready for operation with a 400V three-phase plug. Please verify if the type of current, voltage and protection fuse correspond to the values specified. A protective earth ground wire connection must be available. Mains fuse 10A to 16A.

Make sure that the direction of rotation of the drive motor is correct. In the switch position of the rotary direction switch of counter clockwise rotation (L), the spindle should rotate counter clockwise. If necessary two phase terminals on three-phase connector or your three-phase connection must be exchanged.

## WARNING!

The three-phase electrical connection may only be performed by an electrician or under the guidance and supervision of an electrician.

🔗 Qualification on page 10

🔗 Schaltplan - Wiring diagram on page 99



## CAUTION!

Arrange the machine's connection cable in such a way that it will not cause a tripping hazard.



## 3.8 Warming up the machine

### ATTENTION!

If the lathe and in particular the lathe spindle are immediately operated at maximum load when cold, this may result in damages.



### INFORMATION

For a long service life of your lathe, during the first operating hours, we recommend that you do not exceed a maximum revolution speed of 500 rpm. If the machine is cold, e.g. directly after having transported the machine, it should be warmed up at a spindle speed of only 500 1/min for the first 30 minutes.



MACHINERYHOUSE





## 4 Operation

### 4.1 Control and indicating elements

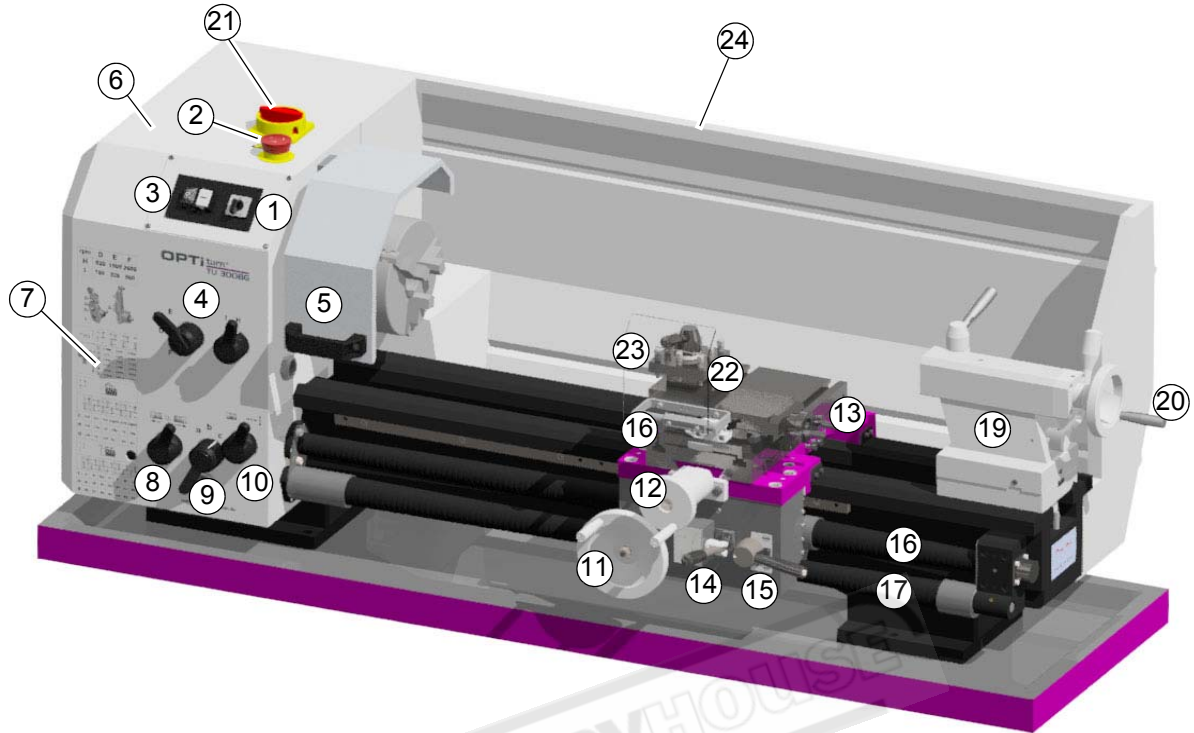

Img.4-1: TU3008G

Pos.	Designation	Pos.	Designation
1	Rotation direction switch	2	Emergency-stop button
3	ON/ OFF switch	4	Selector lever speed adjustment
5	Lathe chuck protection	6	Protective cover of the headstock
7	Change wheel and feed table	8	Selector switch for feed direction
9	Selector switch for feed speed	10	Selector switch, longitudinal feed with lead screw, cross feed with feed rod
11	Handwheel lathe saddle	12	Handwheel cross slide
13	Handwheel top slide	14	Longitudinal feed, cross feed engagement lever
15	Threading engaging lever	16	Lead screw
17	Feed rod	19	Tailstock
20	Tailstock sleeve hand wheel	21	Main switch
22	Quadruple toolholder	23	Chip guard shield
24	Splash guard		



## 4.2 Safety

Commission the lathe only under the following conditions:

- The lathe is in proper working order.
- The lathe is used as prescribed.
- Follow the operating instructions.
- All safety devices are installed and activated.

Eliminate or have all malfunctions rectified promptly. Stop the lathe immediately in the event of any abnormality in operation and make sure it cannot be started-up accidentally or without authorisation. Notify the person responsible immediately of any modification.



☞ Safety during operation on page 14

### 4.2.1 Overview of the control elements

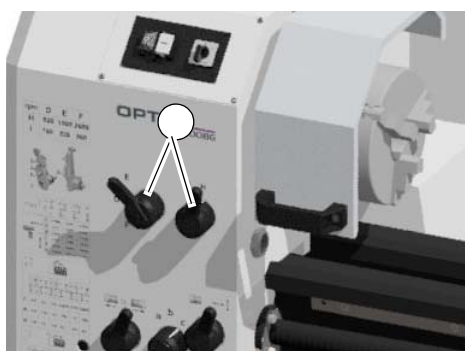

Speed setting

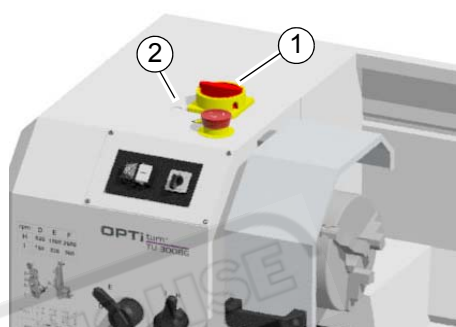

Main switch ( 1 ) and "Reset" of the motor circuit breaker ( 2 )

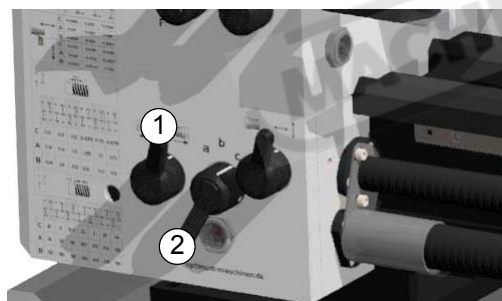

Feed direction (1)  
Infeed speed (2)

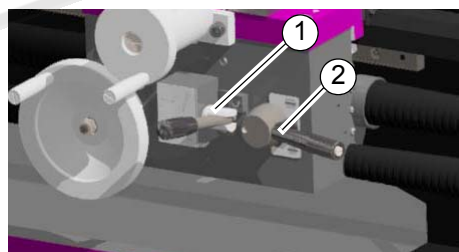

Longitudinal feed, cross feed engagement lever (1)  
Thread cutting engagement lever (2)

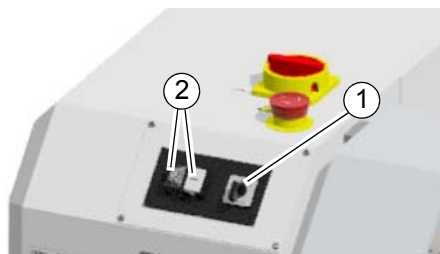

Rotation direction switch (1)  
On / Off switch (2)

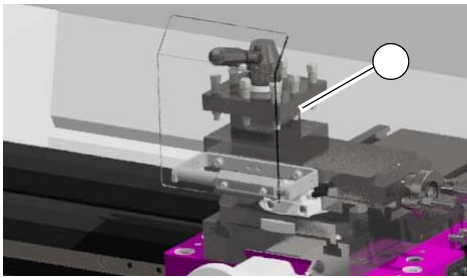

Tool holder

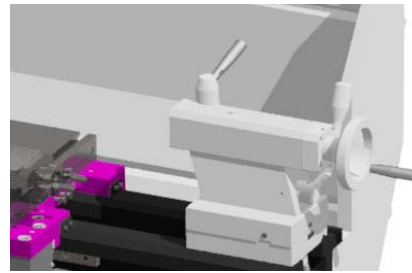

Tailstock

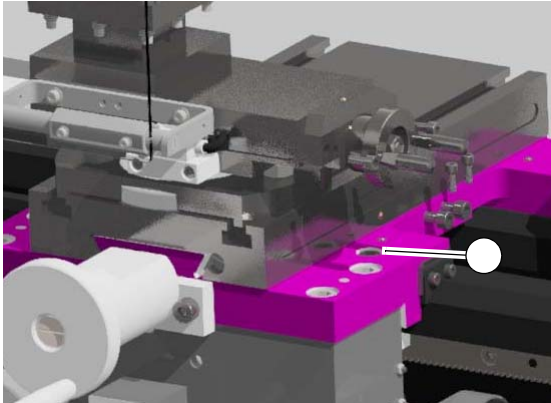

Attachment screw lathe saddle

## 4.2.2 Overview of indicator elements

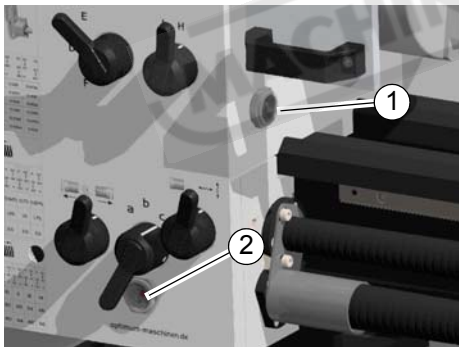

- ( 1 ) Oil sight glass speed gear unit
- ( 2 ) Oil sight glass feed gear

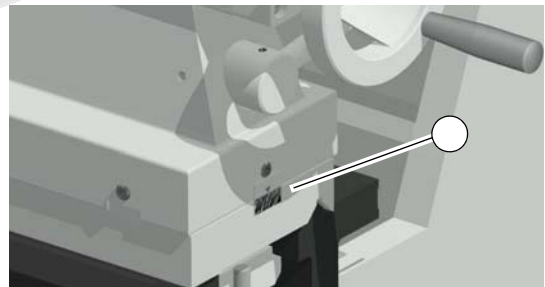

Scale cross offset tailstock



## 4.2.3 Control elements



Turning direction

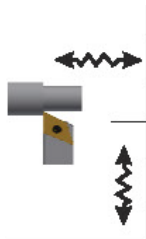

Longitudinal feed / cross feed

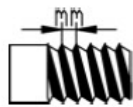

Metric thread [ mm / spindle revolution ]



Feed direction



Position clamp bolt on the lathe spindle holding fixture



Spindle rotation On / Off

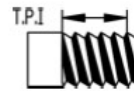

Inch thread [ threads / inch ]



mm per spindle revolution



Oil fill, oiling

## 4.3 Switching on the machine

### 4.3.1 Switching on

- ➔ Check that the emergency-stop button is not pressed or is unlocked. Turn the emergency-stop button to the right in order to unlock it. Emergency-stop switch on page 12
- ➔ Close the lathe chuck protection.
- ➔ Select turning direction.
- ➔ Switch on spindle rotation.
- Malfunctions on page 104



#### 4.4 Switching the machine off

- Press push button "Off" or set the rotation direction switch to the neutral central position.
- If the lathe has been shut off for a longer period of time, switch it off using the main switch and secure it against being unintentionally switched on again or pull the power plug.
  - ☞ Disconnecting and securing the lathe on page 15

#### CAUTION!

The emergency stop button may only be activated in an emergency. You should not use the EMERGENCY STOP button to stop the machine during normal operation.



#### 4.5 Resetting an emergency stop condition

- Unlock the emergency stop button again.
- Set the rotation direction switch to the neutral central position.
- Select turning direction.
- Switch on spindle rotation.

#### 4.6 Resetting the motor circuit breaker

When the motor has been overloaded.

- Activate the motor circuit breaker again. Press the reset button.

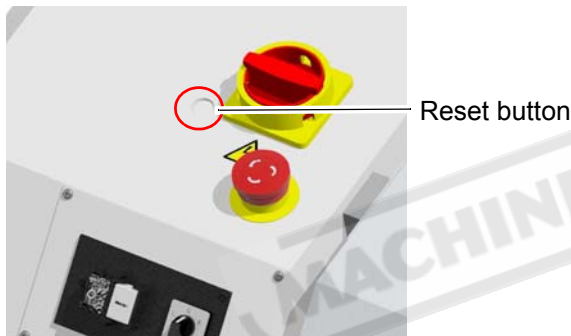

#### INFORMATION

Make sure that the cutting forces are not too large. The motor circuit breaker triggers before the three-phase motor stops due to overloading, or the V-belt slips through overload and burns. The motor circuit breaker is adjustable. You get the highest torque on the spindle at the lowest speed.



#### CAUTION!

The setting of the motor circuit breaker may only be performed by a qualified electrician. If the V-belt slips and the motor circuit breaker is not tripped, the setting of the motor circuit breaker is incorrect.



- ☞ V-belt check, re-tighten on page 71

Incorrect operation due to high cutting forces in connection with an incorrect setting of the motor circuit breaker, cause damage to the electrical system and the V-belt.

#### 4.7 Power failure, Restoring readiness for operation

- Set the rotation direction switch to the neutral central position.
- Select turning direction.
- Switch on spindle rotation.



## 4.8 Speed setting

### ATTENTION!

Only change gear positions when the lathe is being completely stopped.

A speed change is done by setting the shift lever at the speed gear unit.



## 4.9 Fixing the lathe saddle

### ATTENTION!

The cutting force produced during facing, recessing or slicing process may displace the lathe saddle.

→ Secure the lathe saddle using the tightening screw.

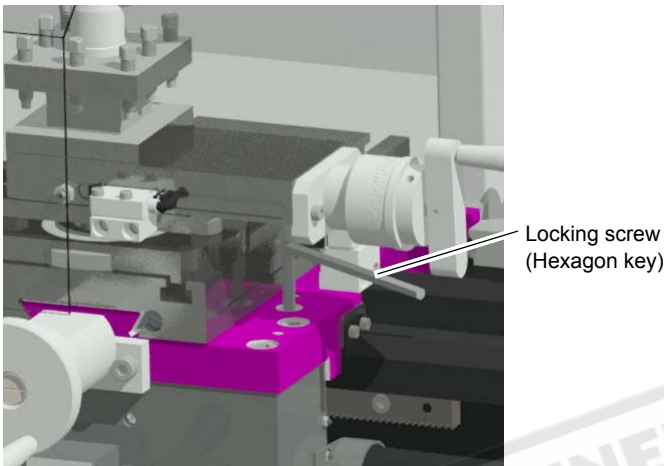

Img.4-2: Lathe saddle

## 4.10 Changing the feed rate

### 4.10.1 Selector switch

Use the selector rotary switches to select the feed direction and feed speed.

### ATTENTION!

Wait until the machine has come to a complete stop before making any change to the selector levers.

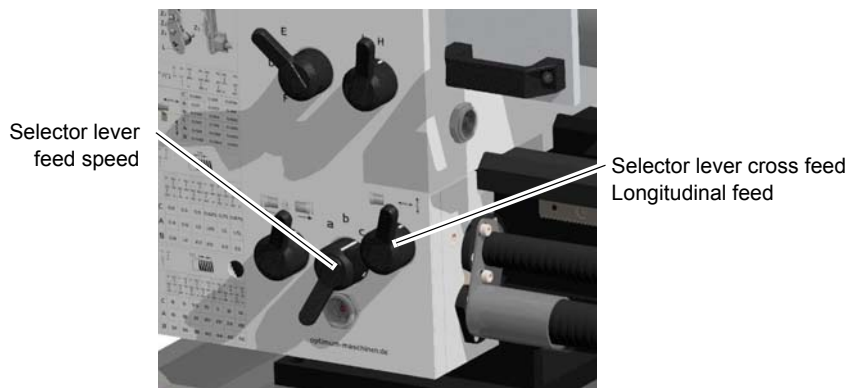

Img.4-3: Changing the feed rate

### INFORMATION

Use the table on the lathe for selecting the feed speed or the thread pitch. Replace the change gears if the required thread pitch or feed cannot be obtained with the installed gear set.



TU3008G\_GB\_4.fm



#### 4.10.2 Changing the change gears

The change gears for the feed are mounted on a quadrant.

- Disconnect the machine from the electrical supply.
- Loosen the locking screw on the quadrant with a hexagon key.

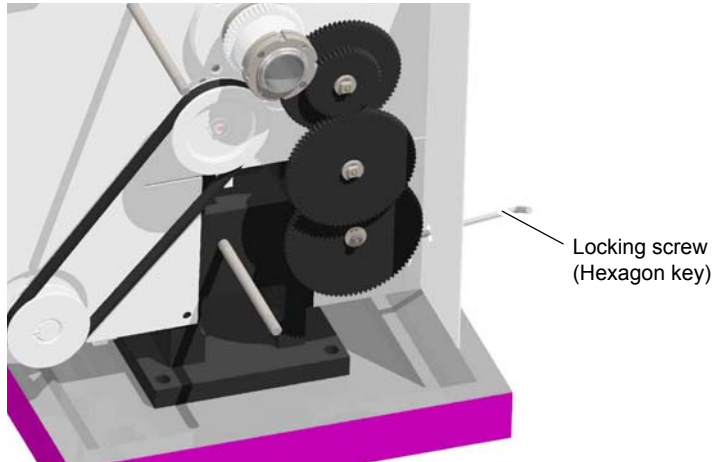

Img.4-4: Locking screw quadrant

- Swing the quadrant to the right.
- Remove the lock washers of the clamping screws at the quadrant.
- Remove the screw from the shaft of the feed gear.

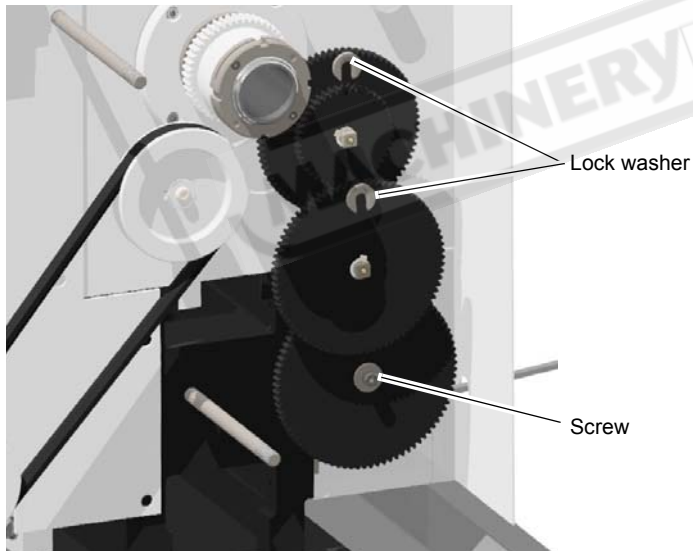

Img.4-5: Attachment of change gears



- Loosen the clamping screws on the quadrant.

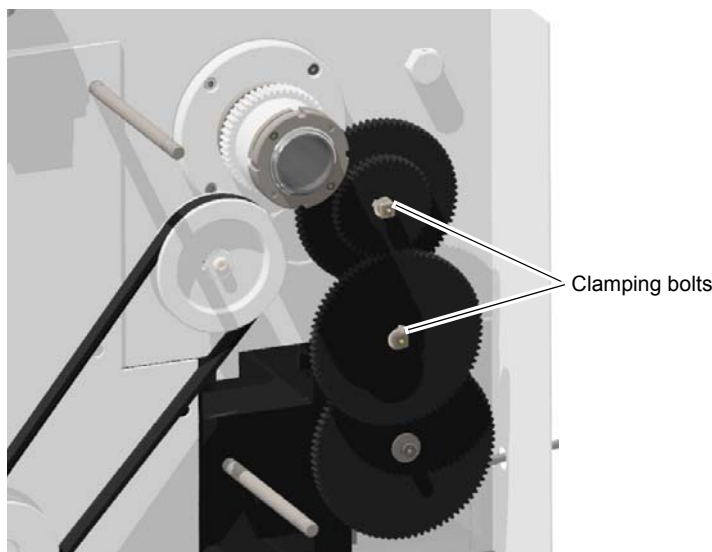

Img.4-6: Attachment of change gears

- Install the gear couples using the feed or change gear table and screw the gearwheels onto the quadrant again.
- Swing the quadrant to the left until the gearwheels have engaged again.
- Re-adjust gear flank clearance by inserting a normal sheet of paper as an adjusting or distance aid between the gearwheels.
- Immobilise the quadrant with the locking screw.
- Attach the protective cover of the headstock and reconnect the machine to the power supply.

MACHINERYHOUSE





### 4.10.3 Feed table, table for thread cutting

The tables are built up in a way that you may later on assemble the required combination to cut a thread without having to look up the details. Ligature as orientation for the coming of one toothed wheel to the following one. The identifier "H" stands for bushing or a small toothed wheel as an auxiliary distance. This smaller toothed wheel as an auxiliary distance must of course not be came in with any other toothed wheel.

The lowest gearwheel is moved using the spacer (bushing), see position 13 on the parts drawing.

The designation **a b c** of the change gear table designates the position of the selector lever on the feed gear.

	C	0.085	0.128	0.208
	A	0.171	0.257	0.416
	B	0.342	0.514	0.832
	C	0.010	0.016	0.025
	A	0.021	0.032	0.050
	B	0.042	0.064	0.100

	C	0.2	0.3	0.5	0.625	0.75	0.875
	A	0.4	0.6	1.0	1.25	1.5	1.75
	B	0.8	1.2	2.0	2.5	3.0	3.5

	C	8	9	9.5	10	11	12	14
	A	16	18	19	20	22	24	28
	B	32	36	38	40	44	48	56

### 4.11 Cross feed, longitudinal feed engagement lever

#### ATTENTION!

**Damage to mechanical parts. The automatic feed is not designed to move onto mechanical stops or the mechanical end of the headstock.**

The automatic feed and the feed for thread cutting are activated and deactivated using the engagement lever.

The automatic feed for turning is performed with the feed rod.

The feed for thread cutting is performed with the lead screw.

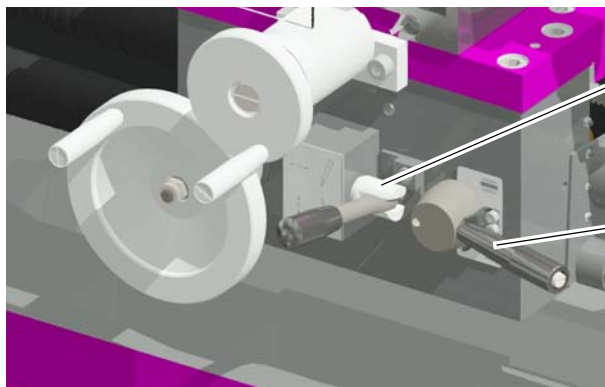

Cross feed and longitudinal feed engagement lever

Threading engaging lever

Img.4-7:

Apron

TU3008G\_GB\_4.fm



## INFORMATION

Move the hand wheel of the lathe saddle a little in order to facilitate the locking of the engaging lever.



### 4.12 Tool holder

Clamp the lathe tool into the tool holder.

The lathe tool needs to be clamped as short and tight as possible when turning in order to be able to absorb the cutting force during the chip formation well and reliably.

Adjust the height of the tool. Use the tailstock with the centering point in order to determine the required height. If necessary, put the steel washers beneath the lathe tool to achieve the required height.

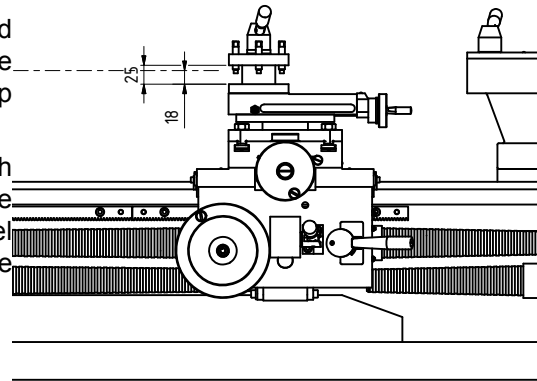

Img.4-8: Height up to the turning centre 18mm

### 4.13 Lathe spindle fixture

#### WARNING!

**Do not clamp any workpieces that exceed the permitted chucking capacity of the lathe chuck. The clamping force of the chuck is too low if its capacity is being exceeded. The clamping jaws may loosen.**



**Only use lathe chucks designed for the speed of the machine.**

**Do not use lathe chucks with an external diameter that is too large.**

**Please ensure that lathe chucks are manufactured to EN 1550 standards.**

The spindle is designed as Camlock DIN ISO 702-2 no.4 holding fixture.

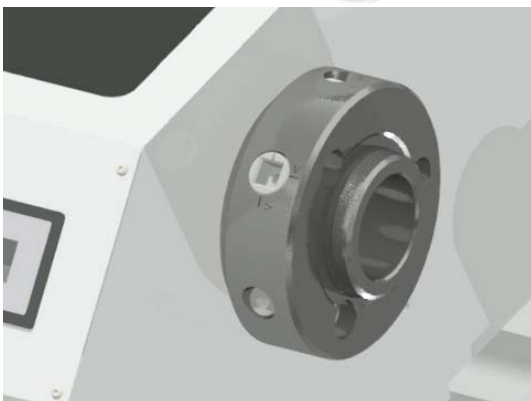



## Fasten workpiece holder

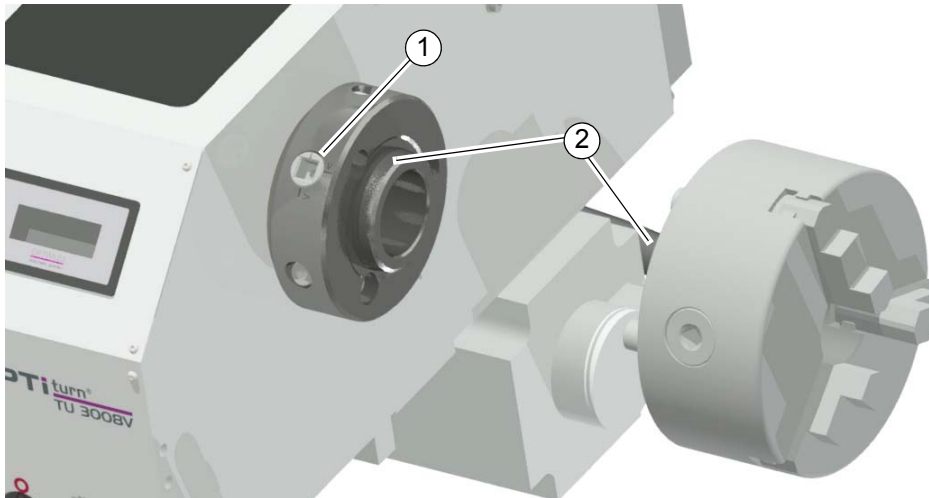

Img.4-9: Fasten workpiece holder

- Turn clamp bolts (1) into the open position.
- Clean the taper attachment on the lathe chuck and the spindle fixture.
- Fit lathe chuck.
- Turn the clamp bolts (1) to the closed position.

### CAUTION!

If the reference mark on the clamp bolt is not between the two V markings, the chuck must be removed and this bolt (D) must be re-adjusted.



- Fasten the workpiece holder by turning the clamping bolts clockwise.

The right clamp position is reached when the reference marker at the clamp holder are between the two marks at the lead spindle seat.

The tightening torque must be approximately 80 Nm, otherwise the rotational accuracy of the lathe chuck is not present. 100 Nm is about the torque used for aluminum rims on cars.

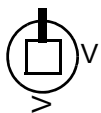

Marking clamp bolt  
"Open position"



Marking clamp bolt  
"Closed position"

Img.4-10: Marking clamp bolt

### 4.13.1 Adjusting the Camlock bolts to the workpiece holder

Insert all of the bolts in the screwed flange of the chuck, until the reference mark, the circular reference line (F) is in line with the wall of the chuck flange surface and the semicircular grooves are in line with the holes of the safety screw (E).

- Fit the safety screw (E) into each bolt and tighten.
- Make sure that the two contact sides (plate and shaft) are free from impurities.

Now the chuck can be mounted.

Before coupling the chuck to the shaft nose, check that the clamp bolts are in an unlocked position.

- Fasten the workpiece holder by turning the clamping bolts clockwise.



## INFORMATION

The reference mark (F) on each Cam-lock bolt serves as an orientation for the correct adjustment.

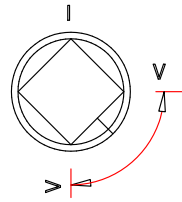
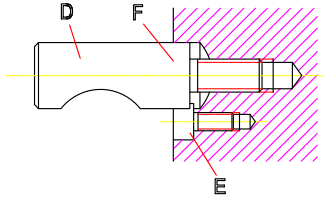

Img.4-11: Cam-lock fixture

## 4.13.2 Replacing the clamping jaws on the lathe chuck

### CAUTION!

The correct position of the clamping jaws is correct if after twisting together of the chuck jaws are centered at the center.



The clamping jaws and the three-jaw chuck are equipped with numbers. Nevertheless check before the change, if the numbers are readable - if necessary - check the jaws and their original position. Insert the clamping jaws at the correct position and in the right order into the three-jaw chuck. Do not confuse additional markings on the lathe chuck with number sequences.

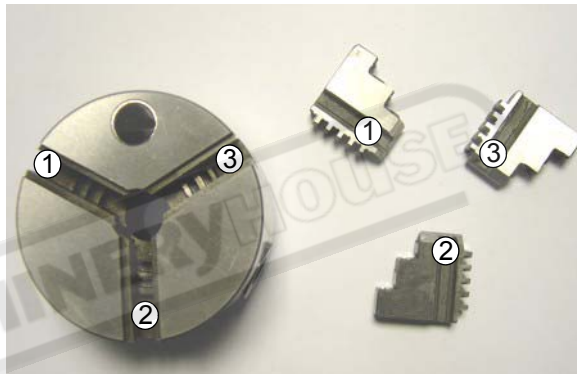

Img.4-12: Three-jaw chuck / clamping jaws



## 4.13.3 Clamping a workpiece into the three jaw chuck

When the workpiece is being clamped unprofessionally, there is a risk of injury as the workpiece may fly off or the jaws may break. The following examples do not show all possible situations of danger.

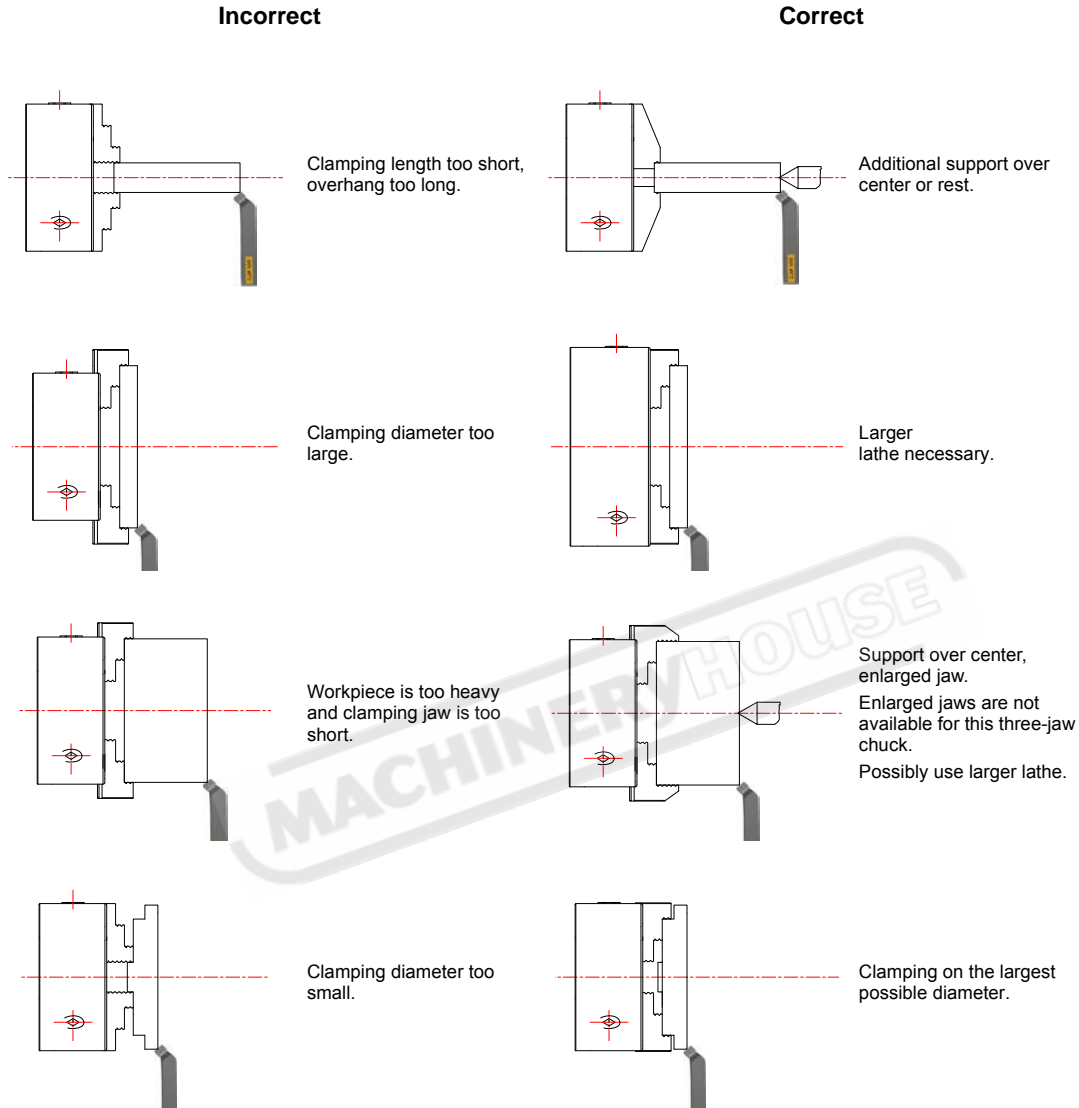

## 4.14 Taper turning

### 4.14.1 Taper turning with the top slide

With the top slide short cone can be rotated. The scaling is performed up to 60° degree of angle. It is also possible to adjust the top slide over the 60°- angular mark.

- ➔ Loosen the two nuts at the left and right of the top slide.
- ➔ Swivel the top slide.
- ➔ Clamp the top slide again.



## 4.14.2 Taper turning with the tailstock

The cross-adjustment of the tailstock is used for turning long, thin bodies.

- Loosen the locking nut of the tailstock.
- Unscrew the locking screw approximately half a turn.

By alternately loosening and tightening the two (front and rear) adjusting screws, the tailstock is moved out of the central position. The desired cross-adjustment can be read off the scale.

- First retighten the locking screw and then the two (front and rear) adjusting screws.  
Retighten the adjusting screws of the tailstock.

### CAUTION!

**Check clamping of the tailstock and the sleeve, respectively for the turning jobs between the centres!**

**Tighten the securing screw at the end of the lathe bed in order to prevent the tailstock from unintentional drawing-out of the lathe bed.**

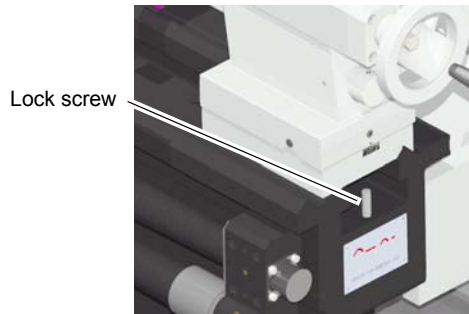

Img.4-13: Lathe bed

## 4.14.3 Turning of cones with high precision



Abb.4-14: Designation on the cone

- D = large diameter [mm]
- d = small diameter [mm]
- L = cone length [mm]
- Lw = workpiece length [mm]
- $\alpha$  = cone angle
- $\alpha/2$  = setting angle
- Kv = cone proportion
- Vr = tailstock offset
- Vd = measure change [mm]
- Vo = twist measure of top slide [mm]

There are different possibilities to machine a cone on a common small lathe:

1. By twisting the top slide by setting the setting-angle with the angular scale. But there the graduation of the scale is too inaccurate. For chamfers and conic passages the graduation of the angular scale is sufficient.
2. By a simple calculation, a stop measure of 100mm length (of your own production) and a gauge with stand.

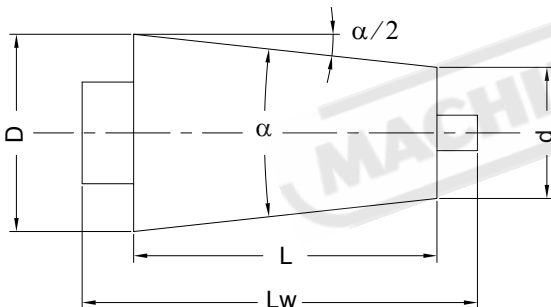
### Calculation

of the offset of the top slide relating to the stop measure with a length of 100 mm.

Step by step		
$Kv = \frac{L}{D - d}$	$Vd = \frac{100 \text{ mm}}{Kv}$	$Vo = \frac{Vd}{2}$



by one calculation step (summary)

$$V_o = \frac{100 \text{ mm} \times (D - d)}{2 \times L}$$

Example:

D = 30.0 mm ; d = 24.0 mm ; L = 22.0 mm

$$V_o = \frac{100 \text{ mm} \times (30 \text{ mm} - 24 \text{ mm})}{2 \times 22 \text{ mm}} = \frac{100 \text{ mm} \times 6 \text{ mm}}{44 \text{ mm}} = 13.63 \text{ mm}$$

The stop measure (100mm) is to be put between a fixed unit stop and the bedslide. Put the gauge with stand on the lathe bed and horizontally align the test prod with the test prod with the top slide (90° to the top slide). The twisting measure is calculated with the above mentioned formula.

The top slide is twisted by this value (then set the gauge to zero). After removing the stop measure, the bedslide will be aligned to the limit stop. The gauge must indicate the calculated value "Vo" Then the workpiece and the tool are clamped and positioned (the bedslide is fixed). The infeed is performed with the handwheel of the top slide. The depth of cut is advanced with the handwheel of the cross slide.

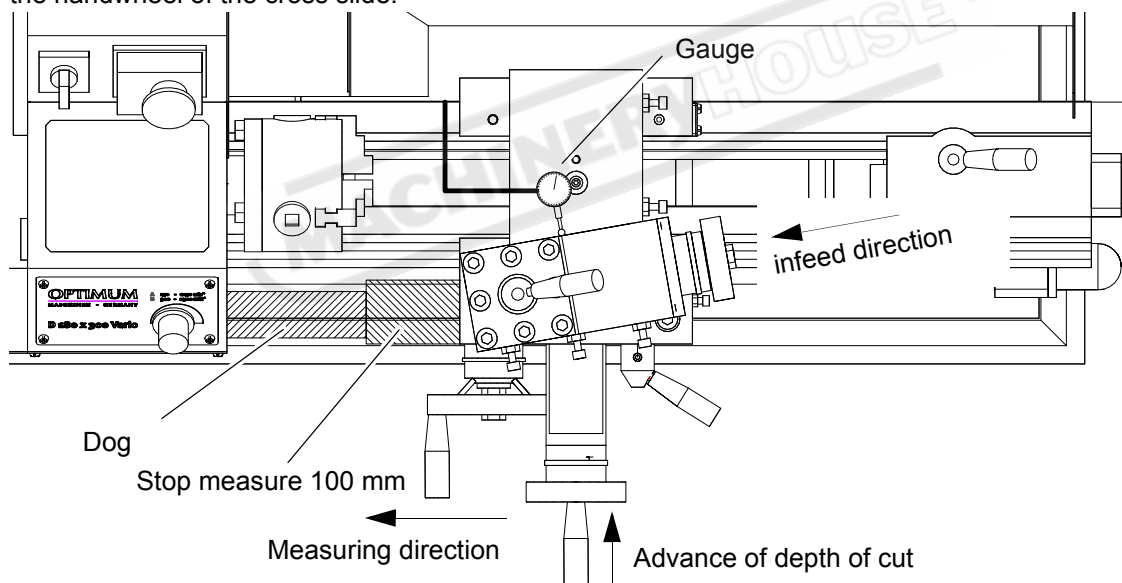

Img.4-15: Cone setting with stop measure

### 3. By measuring an existing cone with gauge and stand.

The stand is put on the top slide. The gauge is aligned horizontally and 90° to the top slide. The top slide is approximately adjusted to the cone angle and the test prod brought in contact with the cone surface (fix the bedslide). Now the top slide is twisted in a way that the gauge does not indicate any travel of the pointer over the whole length of the cone (offset over the handwheel of the top slide).

Then you may start reaming the lathe as described under point 2. The workpiece might be a flange for lathe chucks or a face plate.

TU3008G\_GB\_4.fm

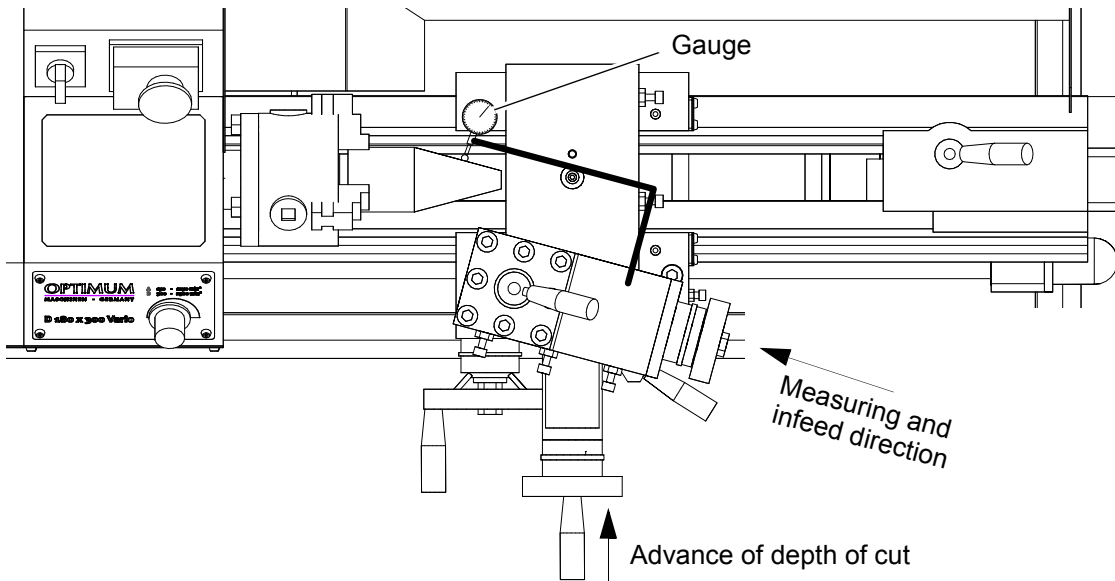

Img.4-16: Cone setting with stop measure

- By offsetting the tailstock as the cone length is larger than the adjustable stroke of the top slide.

The workpiece is clamped between two points, therefore center holes are required on the face. They are to be drilled before removing the lathe chuck. The slaving of the workpiece is performed by a pulling pin and a lathe carrier.

The calculated value "Vr" is the offset measure of the tailstock. The offset is monitored with the gauge (also the return travel).

For this type of cone machining the lowest speed is used !

Annotation:

In order to check the position of the tailstock axis to the rotation axis, a shaft with two centerings is clamped between the points. The stand with the gauge is put on the bedslide. The gauge is aligned 90° to the rotation axis and horizontally brought into contact with the shaft. The gauge will pass along the shaft with the bedslide. There must not be any travel of the pointer along the whole length of the shaft. If a deviation is being shown, the tailstock is to be corrected.

Calculation:

$$V_r = \frac{L_w}{2 \times K_v} \quad \text{or} \quad V_r = \frac{D - d}{2 \times L} \times L_w$$

$$V_{r_{max}} = \frac{L_w}{50}$$

The tailstock offset must not exceed the value "V<sub>rmax</sub>" as the workpiece tumbles!

Example:

K<sub>v</sub> = 1 : 40 ; L<sub>w</sub> = 150 mm ; L = 100 mm

$$V_r = \frac{150}{2 \times 40} = 1.875 \text{ mm}$$

$$V_{r_{max}} = \frac{150}{50} = 3 \text{ mm}$$



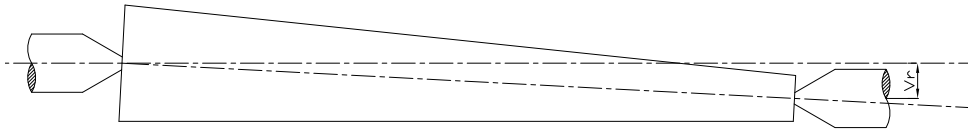

Img.4-17: Workpiece between centres: Tailstock offset Vr

## 4.15 Standard values for cutting data when turning

The better the cutting data are selected, the better the turning result. Some standard values for cutting speeds of different materials are listed on the following pages.

Cutting speed table on page 41

### Criteria of the cutting conditions:

Cutting speed: Vc (m/min)

Depth of cut: ap (mm)

Infeed: f (mm/rev)

### Cutting speed:

In order to get the speed for the machine settings of the selected cutting speeds the following formula is to be applied:

$$n = \frac{V_c \times 1000}{d \times 3.14}$$

Speed: n (rpm)

Workpiece diameter: d (mm)

For lathes without continuously adjustable drive (V-belt drive, speed gear) the nearest speed is being selected.

### Cutting depth:

In order to achieve a good chipping, the results of the depth of cut divided by the feed shall result in a figure between 4 and 10.

Example: ap = 1.0 mm; f = 0.14 mm/rev ; and this equals to in a value of 7.1 !

### Feed:

The feed for rough turning is to be selected in a way that it does not exceed half the value of the corner radius.

Example: r = 0.4 mm ; equals to fmax. = 0.2 mm/rev !

For planing/turning the infeed should be maximum 1/3 of the corner radius.

Example: r = 0.4 mm ; equals to fmax. = 0.12 mm/rev !

## 4.16 Cutting speed table

Materials	Turning								Drilling
	Cutting materials								
	HSS	P10	P20	P40	K10	HC P40	HC K15	HC M15/K10	HSS
non-alloyed steel; steel casting; C45; St37	35 - 50	100 - 150	80 - 120	50 - 100	-	70 - 180	150 - 300	90 - 180	30 - 40

TU3008G\_GB\_4.fm



low-alloy steel, steel casting; 42Cr-Mo4; 100Cr6	20 - - 35	80 - - 120	60 - - 100	40 - - 80	- -	70 - - 160	120 - - 250	80 - - 160	20 - - 30
high-alloyed steel; steel casting; X38CrMoV51; S10-4-3-10	10 - - 20	70 - - 110	50 - - 90	- -	- -	60 - - 130	80 - - 220	70 - - 140	8 - - 15
rust-resistant steel X5CrNi1810; X10CrNiMoTi12	- -	- -	- -	- -	30 - - 80	- -	- -	50 - - 140	10 - - 15
Grey cast iron GG10 ; GG40	15 - - 40	- -	- -	- -	40 - - 190	- -	90 - - 200	70 - - 150	20 - - 30
Cast iron with nodular graphite GGG35 ; GGG70	10 - - 25	- -	- -	- -	25 - - 120	- -	80 - - 180	60 - - 130	15 - - 25
Copper; Brass	40 - - 90	- -	- -	- -	60 - - 180	- -	90 - - 300	60 - - 150	30 - - 80
Aluminium alloys	40 - - 100	- -	- -	- -	80 - - 200	- -	100 - - 400	80 - - 200	40 - - 80

Description of the coated hard metals:

HC P40 = a PVD - coating TiAlN

HC K15 = a CVD - coating TiN-Al<sub>2</sub>O<sub>3</sub> - TiCN - TiN

HC M15/K10 = CVD - coating TiAlN

## 4.17 Terms for the rotating tool

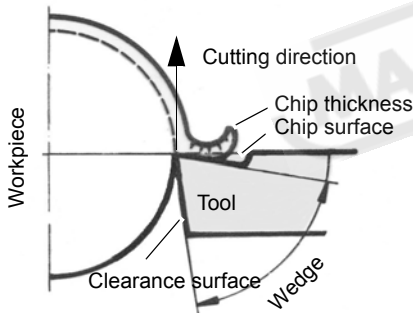

Img.4-18: Geometrically determined cutter for the separation process

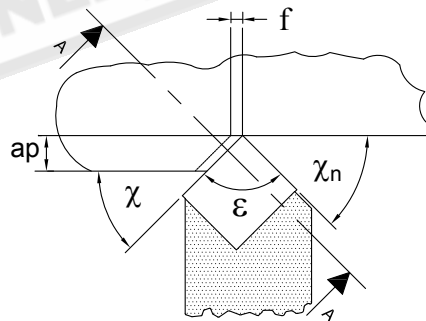

Img.4-19: Cut and chip size

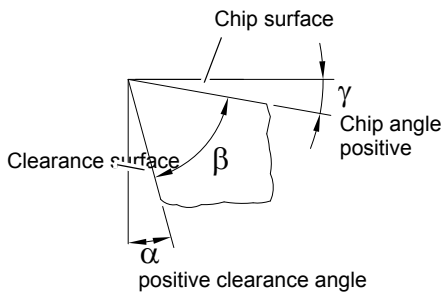

Img.4-20: Cut A - A, positive cutter

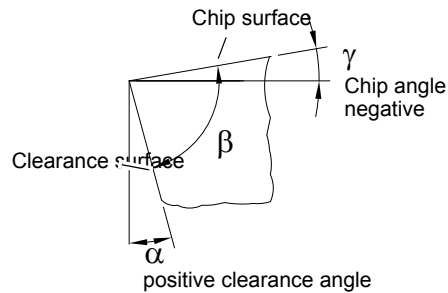

Img.4-21: Cut A - A, negative cutter

TU3008G\_GB\_4.fm



Wedge angle	$\beta$	The following factors influence the chip break when turning	
Chip angle	$\gamma$	Setting angle	$\chi$
Clearance angle	$\alpha$	Corner radius	$r$
Clearance angle minor cutting edge	$\alpha_n$	Cutting edge geometry	
Setting angle	$\chi$	Cutting speed	$V_c$
Setting angle minor cutting edge	$\chi_n$	Depth of cut	$a_p$
Point angle	$\varepsilon$	Feed	$f$
Depth of cut	$a_p$ (mm)		
Feed	$f$ (mm/rev)		

In most cases the setting angle is depending on the work piece. A setting angle of 45° to 75° is suitable for roughing. Setting angle of 90° to 95° (no tendency to chattering) is suitable for planing.

The corner angle serves as passing from the major cutting edge to the minor cutting edge. Together with the infeed it determines the surface quality. The corner radius must not be selected too large as this might result in vibrations.

#### 4.17.1 Cutting edge geometry for turning tools

	High-speed steel		Hard metal	
	Clearance angle	Chip angle	Clearance angle	Chip angle
Steel	+5° to +7°	+5° to +6°	+5° to +11°	+5° to +7°
Cast iron	+5° to +7°	+5° to +6°	+5° to +11°	+5° to +7°
Non-ferrous metal	+5° to +7°	+6° to +12°	+5° to +11°	+5° to +12°
Aluminium alloys	+5° to +7°	+6° to +24°	+5° to +11°	+5° to +24°

#### 4.17.2 Types of cutting form levels

They are needed to influence the chip drain and the chip shape in order to achieve optimum chipping conditions.

##### Examples of types of cutting form levels

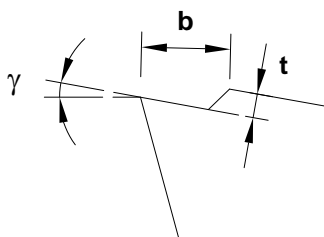

Img.4-22: Cutting form level

$b = 1.0 \text{ mm to } 2.2 \text{ mm}$

$t = 0.4 \text{ mm to } 0.5 \text{ mm}$

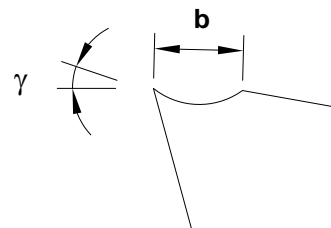

Img.4-23: Cutting form level with fillet

$b = 2.2 \text{ mm with fillet}$



For infeds of 0.05 to 0.5 mm per revolution and depths of cut of 0.2 mm to 3.0 mm.

The different apex angles ( $\varphi$ ) of the cutting form level need to conduct the chip.

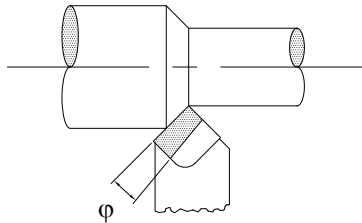

Img.4-24: Positive apex angle for planing

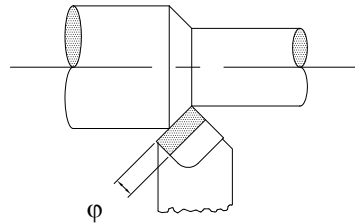

Img.4-25: Neutral apex angle for planing and roughing

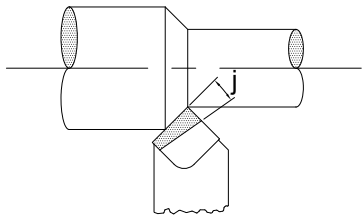

Img.4-26: Negative apex angle for roughing

The ready-ground major cutting edge must be slightly ground with a grindstone for the planing.

For the roughing, a small chamfer must be produced with the grindstone in order to stabilize the cutting edge against striking chips ( $b_f = f \times 0.8$ ).

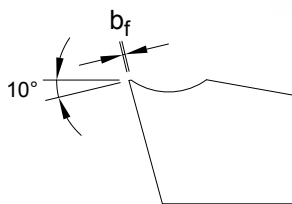

Img.4-27: Stabilize cutting edge



**Polished section for recessing and cutting off**

(for chip angle refer to table)

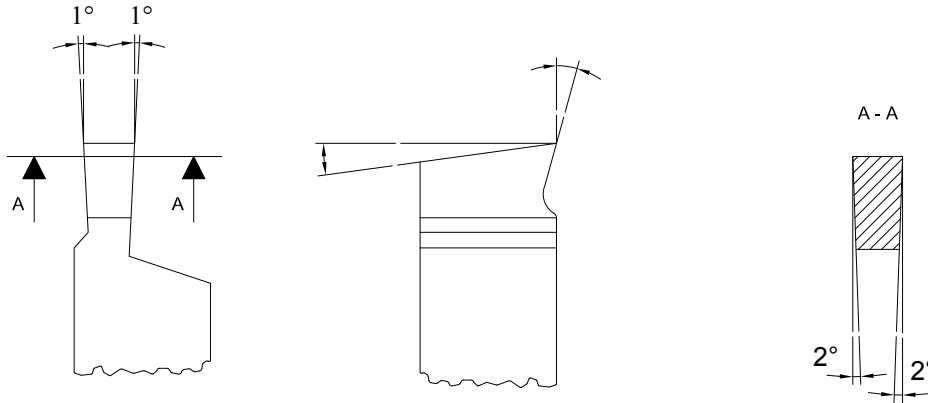

Img.4-28: Polished section recessing and cutting off

**Polished section for threading**

The point angle or the shape for chasing tools is depending on the type of thread.

See also:

- Thread types on page 46
- Pitch angle on page 51

The measure X must be larger than the depth of thread. Make save that no chip angle is being ground as in this case there would be a strain of the profile.

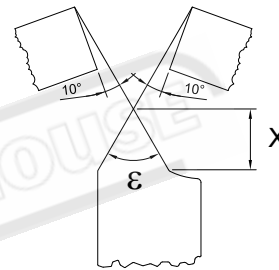

Img.4-29: Polished section for threading

**4.18 Tapping of external and internal threads**

Threads with smaller diameters and standard thread pitches should be tapped manually on the lathe with screw-taps or dies by turning the clamping chuck as this is more simple to produce.

**CAUTION!**

**Pull off the mains plug of the lathe if you want to tap a thread as described above.**

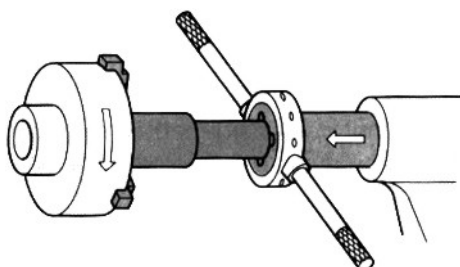

Img.4-30: die

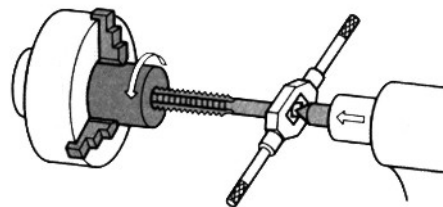

Img.4-31: screw tap

Bolts and nuts with large thread diameters, deviating thread pitches or special types of thread, right-handed and left-handed threads may be produced by threading. For this manufacturing there are as well tool holders and drill rods with exchangeable indexable inserts (one-edged or multiple-edged).

TU3008G\_GB\_4.fm

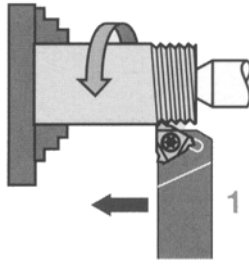

Img.4-32: Tap external thread

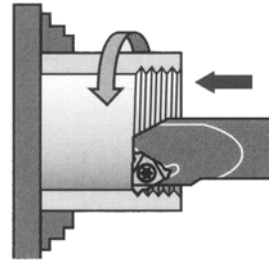

Img.4-33: Tap internal thread

## 4.19 Thread types

Designation	Profile	Code letter	Short term (e. g.)	Application
ISO-thread		M UN UNC UNF UNEF UNS	M4x12  1/4" - 20UNC - 2A  0.250 - UNC - 2A	Machine tools and general mechanical engineering
UNJ		UNJ	1/4" - 20UNJ	Aircraft industry and aerospace industry
Whitworth		B.S.W. W	1/4" in. -20 B.S.W.	Cylindrical threads, Pipe threads, or conical pipe threads for thread connections which seal
ISO-trapezoid thread (one- and multiple-threaded)		TR	Tr 40 x 7 Tr 40 x 14 P7	Motion thread, Leading spindle and transport spindle

TU3008G\_GB\_4.fm



Round thread		RD	RD DIN 405	Fittings and for purposes of the fire brigade
NPT		NPT	1" - 1 1/2" NPT	Fittings and tube joints

### 4.19.1 Metric threads (60° flank angle)

	<p>pitch P</p> <p>depth of thread of the bolt <math>h_2 = 0.6134 \times P</math></p> <p>depth of thread of the nut <math>H_1 = 0.5413 \times P</math></p> <p>rounding <math>r = 0.1443 \times P</math></p> <p>flank diameter <math>d_2 = D_2 - d - 0.6493</math></p> <p>core removing hole drill = <math>d - P</math></p> <p>flank angle = 60°</p>
--	--

#### Metric coarse-pitch thread

Sizes in mm: preferably use the threads in column 1

Denomination of thread $d = D$		pitch P	Flank diameter $d_2 = D_2$	Core diameter		Depth of thread		Rounding r	Core removing hole drill
Column 1	Column 2			Bolt $d_3$	Nut $D_1$	Bolt $h_3$	Nut $H_1$		
M 1		0.25	0.838	0.693	0.729	0.153	0.135	0.036	0.75
	M 1.1	0.25	0.938	0.793	0.829	0.153	0.135	0.036	0.85
M 1.2		0.25	1.038	0.893	0.929	0.153	0.135	0.036	0.95
	M 1.4	0.3	1.205	1.032	1.075	0.184	0.162	0.043	1.1
M 1.6		0.35	1.373	1.171	1.221	0.215	0.189	0.051	1.3
	M 1.8	0.35	1.573	1.371	1.421	0.215	0.189	0.051	1.5
M 2		0.4	1.740	1.509	1.567	0.245	0.217	0.058	1.6
	M 2.2	0.45	1.908	1.648	1.713	0.276	0.244	0.065	1.8
M 2.5		0.45	2.208	1.948	2.013	0.276	0.244	0.065	2.1
M 3		0.5	2.675	2.387	2.459	0.307	0.271	0.072	2.5

TU3008G\_GB\_4.fm



	M 3.5	0.6	3.110	2.764	2.850	0.368	0.325	0.087	2.9
M 4		0.7	3.545	3.141	3.242	0.429	0.379	0.101	3.3
M 5		0.8	4.480	4.019	4.134	0.491	0.433	0.115	4.2
M 6		1	5.350	4.773	4.917	0.613	0.541	0.144	5.0
M 8		1.25	7.188	6.466	6.647	0.767	0.677	0.180	6.8
M 10		1.5	9.026	8.160	8.376	0.920	0.812	0.217	8.5
M 12		1.75	10.863	9.853	10.106	1.074	0.947	0.253	10.2
	M14	2	12.701	11.546	11.835	1.227	1.083	0.289	12
M 16		2	14.701	13.546	13.835	1.227	1.083	0.289	14
	M18	2.5	16.376	14.933	15.294	1.534	1.353	0.361	15.5
M 20		2.5	18.376	16.933	17.294	1.534	1.353	0.361	17.5
	M 22	2.5	20.376	18.933	19.294	1.534	1.353	0.361	19.5
M 24		3	22.051	20.319	20.752	1.840	1.624	0.433	21
	M 27	3	25.051	23.319	23.752	1.840	1.624	0.433	24
M 30		3.5	27.727	25.706	26.211	2.147	1.894	0.505	26.5
M 36		4	33.402	31.093	31.670	2.454	2.165	0.577	32
M 42		4.5	39.077	36.479	37.129	2.760	2.436	0.650	37.5
M 48		5.5	44.752	41.866	41.866	3.067	2.706	0.722	43
M 56		5.5	52.428	49.252	49.252	3.374	2.977	0.794	50.5
M 64		6	60.103	56.639	56.639	3.681	3.248	0.866	58

Metric fine-pitch thread

Denomination of thread d x P	Flank diameter d2 = D2	Core diameter		Denomination of thread d x P	Flank diameter d2 = D2	Core diameter	
		Bolt	Nut			Bolt	Nut
M2 x 0.2	1.870	1.755	1.783	M16 x 1.5	15.026	14.160	14.376
M2.5 x 0.25	2.338	2.193	2.229	M20 x 1	19.350	18.773	18.917
M3 x 0.35	2.773	2.571	2.621	M20 x 1.5	19.026	18.160	18.376
M4 x 0.5	3.675	3.387	3.459	M24 x 1.5	23.026	22.160	22.376
M5 x 0.5	4.675	4.387	4.459	M24 x 2	22.701	21.546	21.835
M6 x 0.75	5.513	5.080	5.188	M30 x 1.5	29.026	28.160	28.376
M8 x 0.75	7.513	7.080	7.188	M30 x 2	28.701	27.546	27.835
M8 x 1	7.350	6.773	6.917	M36 x 1.5	35.026	34.160	34.376
M10 x 0.75	9.513	9.080	9.188	M36 x 2	34.701	33.546	33.835
M10 x 1	9.350	8.773	8.917	M42 x 1.5	41.026	40.160	40.376
M12 x 1	11.350	10.773	10.917	M42 x 2	40.701	39.546	39.835
M12 x 1.25	11.188	10.466	10.647	M46 x 1.5	47.026	46.160	46.376
M16 x 1	15.350	14.773	14.917	M48 x 2	46.701	45.546	45.835





## 4.19.2 British thread (55° flank angle)

BSW (Ww.): British Standard Withworth Coarse Thread Series is the most common coarse thread in Great Britain and corresponds in its usage category to the metric coarse-pitch thread. The designation of a hexagon head screw 1/4" - 20 BSW x 3/4" , is here: . 1/4" is the nominal diameter of the screw and 20 is the number of threads in 1" of length

BSF: British Standard Fine Thread Series. British Standard Fine Thread Series. BSW- and BSF are the thread selection for the common screws. This fine thread is very common in the British machine tool industry, but it is replaced by the American UNF thread.

BSP (R): British Standard Pipe Thread. Cylindric pipe thread; designation in Germany: R 1/4" (nominal width of the tube in inch). Tube threads are larger in their diameter as "BSW". Designation 1/8" - 28 BSP

BSPT: BSPT: British Standard Pipe - Taper Thread. Conic tube thread, cone 1:16; designation: 1/4" - 19 BSPT

BA: BA: British Association Standard Thread (47 1/2° flank angle). Common with instruments and watches, is being replaced by the metric ISO thread and by the ISO miniature thread. It consists of numeric designations from 25 to 0=6.0 mm max diameter.

**Table of the British threads**

Nominal diameter of the thread		Threads in 1"				Threads in 1"		
		BSW	BSF:	BSP/BSPT		BA-threads		
Inch	mm			(R)	D. [mm]	No.		D. [mm]
		55° Flank angle				47 1/2° Flank angle		
1/16	1.588	60	-	-	-	16	134	0.79
3/32	2.382	48	-	-	-	15	121	0.9
1/8	3.175	40	-	28	9.73	14	110	1.0
5/32	3.970	32	-	-	-	13	102	1.2
3/16	4.763	24	32	-	-	12	90.9	1.3
7/32	5.556	24	28	-	-	11	87.9	1.5
1/4	6.350	20	26	19	13.16	10	72.6	1.7
9/32	7.142	20	26	-	-	9	65.1	1.9
5/16	7.938	18	22	-	-	8	59.1	2.2
3/8	9.525	16	20	19	16.66	7	52.9	2.5
7/16	11.113	14	18	-	-	6	47.9	2.8
1/2	12.700	12	16	14	20.96	5	43.0	3.2
9/16	14.288	12	16	-	-	4	38.5	3.6
5/8	15.875	11	14	14	22.91	3	34.8	4.1
11/16	17.463	11	14	-	-	2	31.4	4.7
3/4	19.051	10	12	14	26.44	1	28.2	5.3
13/16	20.638	10	12	-	-	0	25.3	6.0



7/8	22.226	9	11	14	30.20
15/16	23.813	9	11	-	-
1"	25.401	8	10	11	33.25
1 1/8	28.576	7	9	-	-
1 1/4	31.751	7	9	11	41.91
1 3/8	34.926	6	8	-	-
1 1/2	38.101	6	8	11	47.80
1 5/8	41.277	5	8	-	-
1 3/4	44.452	5	7	11	53.75
1 7/8	47.627	4 1/2	7	-	-
2"	50.802	4 1/2	7	11	59.62

### 4.19.3 Indexable inserts

For indexable inserts there are partial profile and full profile indexable inserts. The partial profile indexable inserts are designed for a certain pitch range (e.g. 0.5 - 3 mm).

- The partial profile indexable insert is optimally appropriate for the single-piece production.
- The full profile indexable insert is only designed for a certain pitch.

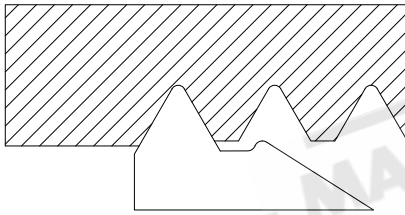

Img.4-34: partial profile indexable insert

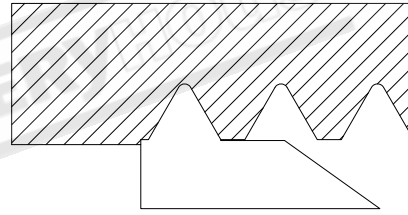

Img.4-35: full profile indexable insert

### Determining the machining method of right-handed and left-handed threads:

Right-handed tool holders or drill rods are used. In order to tap right-handed threads the feed direction towards the clamping chuck is selected and the machine spindle turns to the right (the turning direction of the machine spindle is determined when you look into the spindle from the rear side). If a left-handed thread is to be tapped, the feed direction is selected away from the clamping chuck in direction to the tailstock and the machine spindle turns to the right.

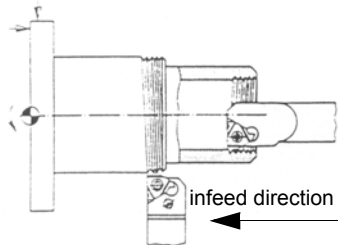

Img.4-36: right-handed thread with the machine spindle turning to the right

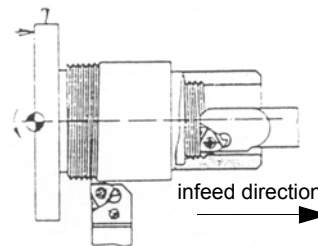

Img.4-37: left-handed thread with the machine spindle turning to the right

As for thread cutting there are other conditions as for longitudinal turning, the forward cutter must show a larger clearance as the pitch angle of the thread.

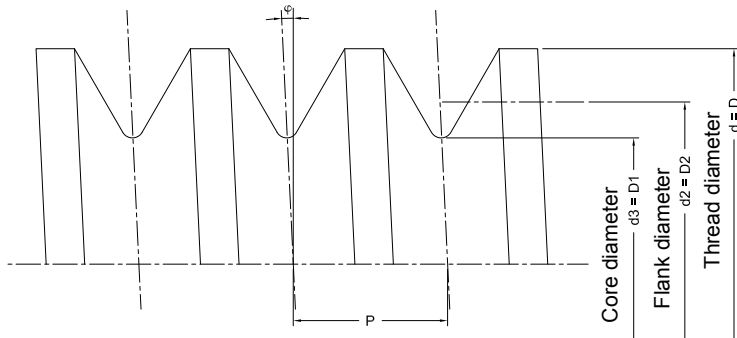

Img.4-38: Pitch angle

Pitch angle  $\varphi$

Pitch  $P$

$$\tan \varphi = \frac{P}{D_2 \times \pi}$$

#### 4.19.4 Examples for thread cutting

As an example, a metric external thread M30 x 1.0 mm made of brass is being machined.

- Steel sheets are to be laid under the complete tool holder or turning tool to achieve exactly the turning center.
- The lowest spindle speed is set so that the lathe will not coast too long !
- Mount gear pairing for pitch 1.0 mm in the change gear !



Abb.4-39: Thread cutting

The outer diameter had been turned to 30.0 mm and the tool holder is clamped in the quadruple holder for threading aligned angular to the rotation axis. The height of centres is checked (as described).

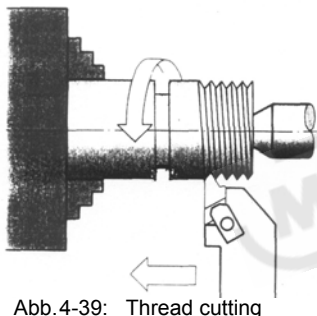

Abb.4-40: radial infeed

The depth of thread is manufactured in various passes. The infeed is to be reduced after each pass.

The first pass takes place with a infeed of 0.1 to 0.15 mm.

For the last pass the infeed shall not be below 0.04 mm.

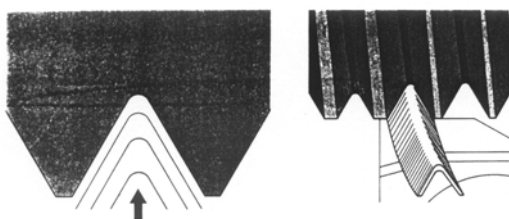
For pitches up to 1.5 mm the infeed may be radial.

For our example 5 to 7 passes are being determined.



Abb.4-41: Alternately infeed

For larger pitches the alternately flank infeed is selected. The top slide is from the 2nd passage in each case 0.05 - 0.10 mm adjusted alternately to the left and right. The last two passes are performed without lateral offset. When the depth of thread is achieved, two passes are performed without infeed.

To machine internal threads, about 2 passes shall be selected additionally for the infeed (drill rods are more instable).

The cutting point is slit slightly by turning the handwheel of the cross slide the scale is turned to zero. This is the point of departure for the infeed of the depth of thread.

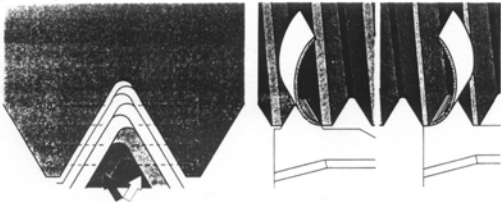
The scale of the top slide is also set to zero (this is important for the lateral offset when turning threads with larger pitches).

The cutting point is set just in front of the starting point of the start of the thread by actuating the handwheel of the lathe saddle.

In standstill of the lathe a connection to the lead-screw is made by shifting the operating lever of the lead-screw nut. With this connection, the adjusted thread pitch is transferred to the lathe saddle and to the tool holder.

## ATTENTION!

**This connection must not be disconnected until the thread is finished !**

### Starting the threading:

- Radial infeed over the handwheel of the cross slide.
- Switch the direction of rotation to counter clockwise rotation.
- Start the machine and have the first cutting process run.



## ATTENTION!

**Always have the thumb ready on the OFF-switch in order to prevent a collision with the workpiece or with the lathe chuck !**

- Immediately switch off the machine at the run out of the thread and cam the cutter out by turning the handwheel of the cross slide.
- Switch the direction of rotation to clockwise rotation.
- Switch the machine on; move the lathe saddle to the starting point; switch the machine off.
- Radial infeed over the handwheel of the cross slide.
- Switch the direction of rotation to counter clockwise rotation.
- Switch the machine on and have the second cutting process run.
- Repeat this procedure as often as necessary until the depth of thread is achieved.
- To check the thread you may use a thread gauge or a workpiece with an internal thread M30 x 1.0
- If the thread is having the exact size, the thread cutting process may be terminated. Now you may again shift the operating lever of the lead-screw nut in standstill. In this way, the connection between the lead-screw and the lathe saddle is interrupted.
- Now the gearwheels for the longitudinal feed are to be mounted again!





## 4.20 General operating instructions

### 4.20.1 Clamping long workpieces

- through the hollow shaft of the spindle

#### CAUTION!

Long rotating parts that protrude from the hollow shaft of the spindle must be secured by the operator using suitable covers. A cover can be a sleeve that is mounted on the headstock that, as a permanent safety device, completely covers the protruding workpiece.



- between the tips

#### CAUTION!

Long workpieces must be additionally supported. They are supported by the tailstock sleeve and, if necessary, a rest.



- with a lathe dog

#### CAUTION!

When clamping workpieces between the tips of the lathe while using a lathe dog, the existing lathe chuck protection must be replaced with a circular lathe chuck protection.



## 4.21 Mounting of rests

### Follow rest and steady rest

Use steady rest or follow rest to support longer parts and prevent the workpiece from flapping around and flying away.

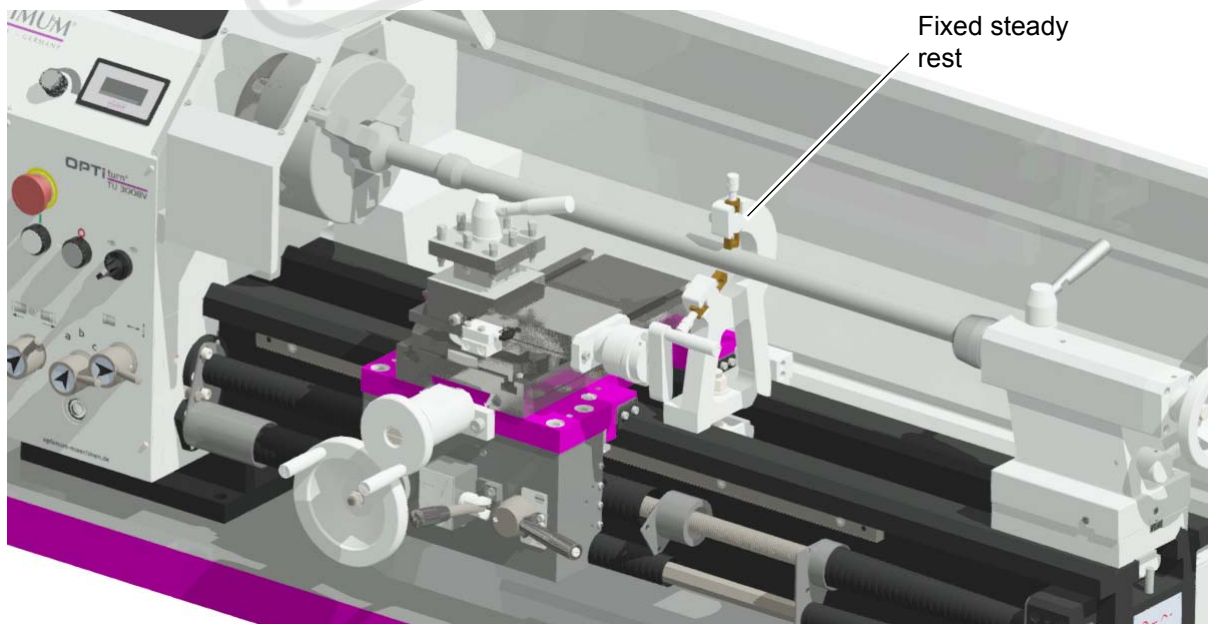

Img.4-42: Fixed steady rest

TU3008G\_GB\_4.fm

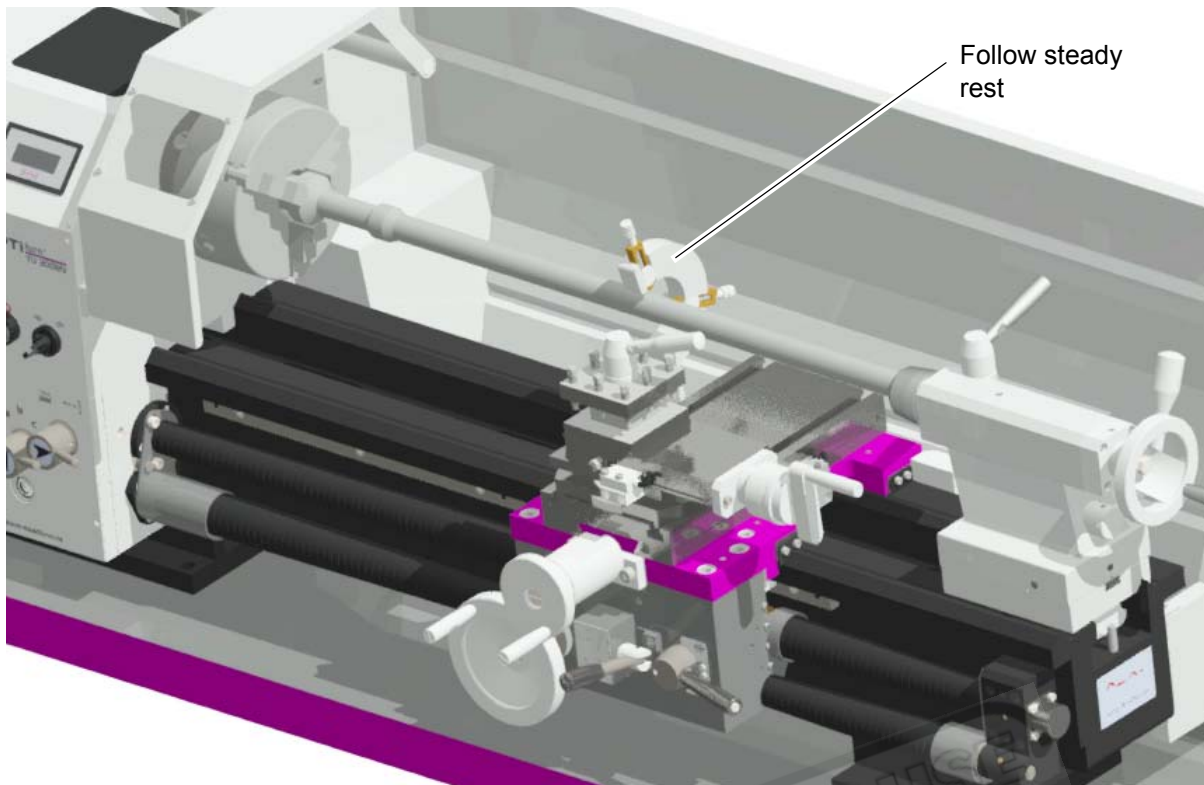

Img.4-43: Follow steady rest

## 4.22 Tailstock

The tailstock quill is used to hold the tools (bits, centres, etc.)

- ➔ Clamp the required tool into the quill of the tailstock.
- Use the scale on the sleeve to re-adjust and / or adjust the tool.
- ➔ Clamp the sleeve with the clamping lever.
- Use the hand wheel to move the sleeve back and forth.

The quill of the tailstock is useable with a drill chuck with countersinking tools.

### INFORMATION

Use the longer fixed centring point from the delivery, so that the centring point can be pressed out again from the tailstock sleeve.



### INFORMATION

When using different tools, it can happen that you cannot start with the quill marking with scale value 0, because the tool is already ejected in this position by the expulsion flap. In such cases we recommend to start at a value of 10mm and to convert from here on.





## 4.22.1 Cross-adjustment of the tailstock

The cross-adjustment of the tailstock is used for turning long, thin bodies.

- ➔ Loosen the adjusting screws in the front and in the rear of the tailstock.
- By alternately loosening and tightening the two (front and rear) adjusting screws, the tailstock is moved out of the central position. The desired cross-adjustment can be read off the scale.
- ➔ Re-tighten the adjusting screws of the tailstock.

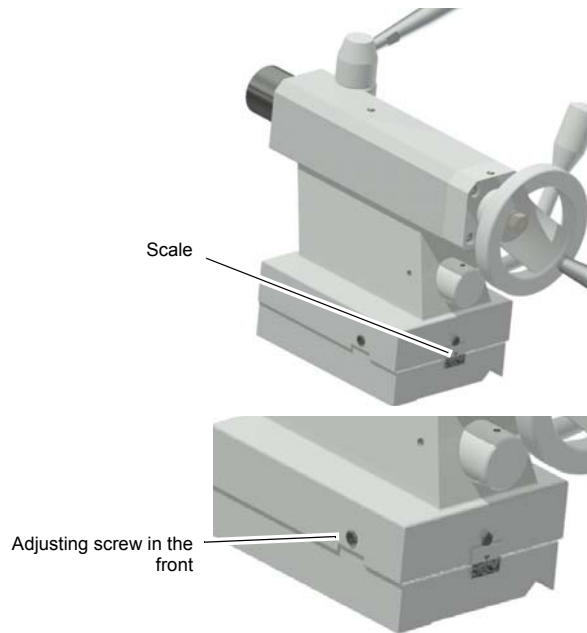

Img.4-44: Cross-adjustment of the tailstock

### INFORMATION

The tailstock may be cross-adjusted to each direction by approximately + - 10mm.

Example:

A 300mm long shaft is to be taper-turned between the centres with an angle of 1°.

Cross-adjustment of the tailstock =  $300\text{mm} \times \tan 1^\circ$ . The tailstock must be cross-adjusted by approximately 5.236mm.



### CAUTION!

**Check clamping of the tailstock and the sleeve, respectively for the turning jobs between the centres!**

**Tighten the securing screw at the end of the lathe bed in order to prevent the tailstock from unintentional drawing-out of the lathe bed.**



Img.4-45: Tailstock



## 4.23 General operating instructions

### 4.23.1 Longitudinal turning

In the straight turning operation, the tool feeds parallel to the axis of rotation of the workpiece. The feed can be either manual - by turning the handwheel on the lathe saddle or the top slide - or by activating the automatic feed. The cross feed for the depth of cut is achieved using the cross slide.

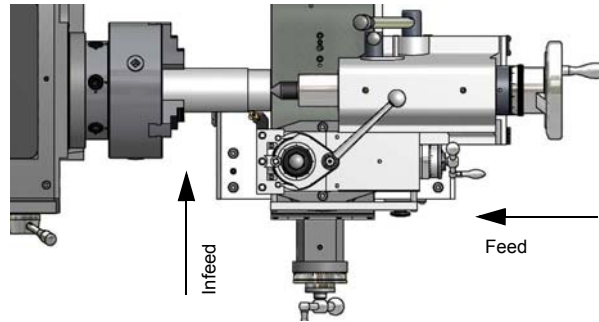

Img.4-46: Graphic: Longitudinal turning

### 4.23.2 Face turning and recessing

In the facing operation, the tool feeds perpendicular to the axis of rotation of the workpiece. Feed is done manually, using the cross-slide hand wheel. The infeed for cut depth is made with the top slide or lathe saddle.

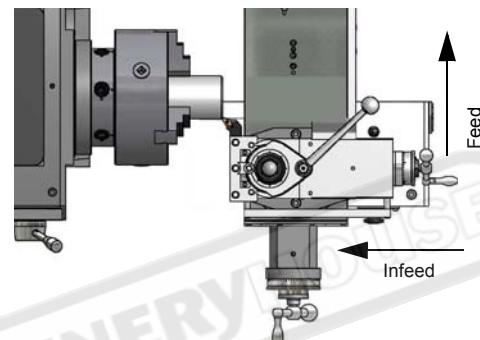

Img.4-47: Graphic: Face turning

### 4.23.3 Turning short tapers with the top slide

Short tapers are turned manually with the top slide. Swivel the top slide to the required angle. The infeed is achieved with the cross slide.

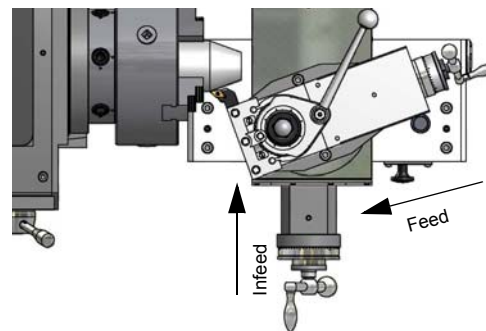

Img.4-48: Graphic: Turning tapers

- ➔ Loosen the two clamping screws in the front and in the rear of the top slide.
- ➔ Swivel the top slide.
- ➔ Clamp the top slide again.





## 4.23.4 Thread cutting

The thread cutting process requires that the operator has a good knowledge of turning and sufficient experience.

### INFORMATION

Due to a safety mechanism, it is not possible to use the

- longitudinal feed via the lead screw and
  - cross feed / longitudinal feed with feed rod
- at the same time.



### NOTES!

#### Example of an external thread:

- The workpiece diameter must have been turned to the diameter of the desired thread.
- The workpiece requires a chamfer at the beginning of the thread and an undercut at the thread run out.
- The speed must be as low as possible.
- The thread cutting tool must be exactly the same shape as the thread, it must be absolutely rectangular and must be clamped in a way that it coincides exactly with the turning centre.
- The threading engaging lever must be engaged during the whole thread cutting process. This does not apply to thread pitches that can be carried out with the thread gauge.
- The thread is produced in various cutting steps in a way that the cutting tool has to be turned out of the thread completely (with the cross slide) at the end of each cutting step.
- The tool is withdrawn with the lead screw nut engaged and the thread cutting tool disengaged by actuating the "Direction of rotation control lever".
- Stop the lathe and feed the thread cutting tool in low cut depths using the cross slide.

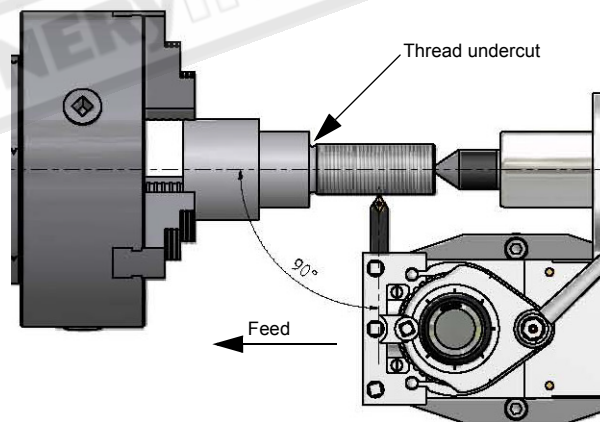

Img.4-49: Illustration: Thread cutting

- Before each passage, place the top slide approximately 0.2 to 0.3 mm to the left and right alternately in order to cut the thread free. In this way, the thread cutting tool cuts only on one thread flank with each passage. Do not execute any more free cutting, just before reaching the full thread depth.



## 4.24 Cooling lubricant

### WARNING!

**Ejection and overflowing of coolants and lubricants. Make sure you do not get the cooling lubricants on the floor. Spilled on the floor cooling agents must be removed immediately.**



Friction during the cutting process causes high temperatures at the cutting edge of the tool.

The tool should be cooled during the milling process. Cooling the tool with a suitable cooling lubricant ensures better working results and a longer service life of the cutting tool.

### INFORMATION

The lathe is lacquered with a **one-component paint**. Consider this fact when selecting your cooling lubricant.



The company Optimum Maschinen Germany GmbH does not assume any guarantee for subsequent damages due to unsuitable cooling lubricants.

The flashpoint of the emulsion must be higher than 140°C.

When using non-water-miscible cooling lubricants (oil content > 15%) with a flashpoint, ignitable aerosol air mixtures might develop. There is a potential danger of explosion.

The selection of cooling lubricants and slideway oils, lubricating oils or greases as well as their care are being determined by the machine operator or operating company.

Therefore, Optimum Maschinen Germany GmbH cannot be held liable for machine damages caused by unsuitable coolants and lubricants as well as by inadequate maintenance and servicing of the coolant. In case of problems with the cooling lubricant and the slideway oil or grease, please contact your mineral oil supplier.

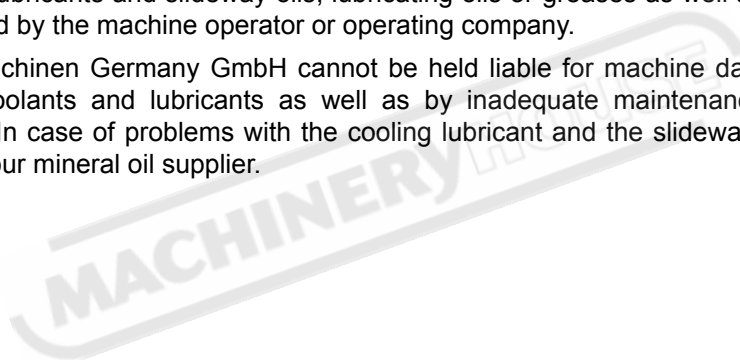



## 4.25 Rotary chuck - K11-160 ISO 702-2

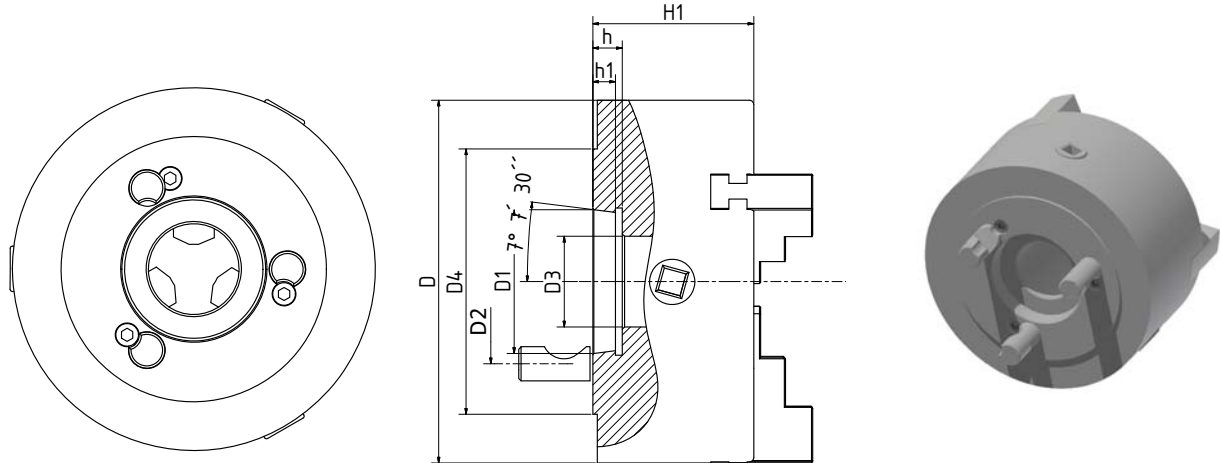

Type		K11-160/D4 ( 3442761 )
Material of the chuck body		Cast steel
Camlock direct fixing (without flange)		DIN ISO 702-2 Size no. 4
Maximum clamping diameter [ mm ]		160
Lathe chuck passage [mm]		40
max. speed [ rpm ]		3000
max. static clamping force $\sum S$ [ kN ]		24
Maximum torque with lathe chuck key [ Nm ]		160
Lathe chuck weight [ kg ]		10
Weight of a jaw [ kg ] with internal grading		0.318
Mass of chuck jaw set [ kg ]		0.954
Centrifugal moment $M_c$ for one jaw [ kgm ] with internal grading		0.0164
Gravity distance $r_o$ of jaw [ mm ]		40.62
D		160
D1		63.513
D2		82.6
D3		50
D4		117
H <sub>1</sub>		71
h		13
h <sub>1</sub>		10

K11-160\_ISO-702-2\_3442761\_ba-integrated\_GB.fm



## 4.25.1 Safety instructions

### Intended use

This standard product is suitable for clamping workpieces on lathe machines and other rotating tooling machines. Unintended and improper use of the manual chuck may cause danger to life and limb of the operator. The specified maximum technical data must not be exceeded while the manual chuck is in operation! The manual chuck should only be used on the basis of its technical data. This also comprises the observance of the conditions of initial operation, assembly, operation as well as conditions of environment and maintenance provided by the manufacturer.

For each individual clamping task, the permitted rotational speed and the necessary clamping force must be determined according to the respective standards that apply and/or the most up-to-date scientific and technological data (e.g. VDI 3106).

### Reasonably foreseeable misuses

Any other use other than that specified under "Intended use" or any use beyond the described use shall be deemed as non-intended use and is not permissible.

Any other use has to be discussed with the manufacturer.

In order to avoid misuse, it is necessary to read and understand the operating instructions before the first commissioning.

The operators must be qualified.

### Avoiding misuse

Improper and unintended use of the manual chuck and disregard of the current safety norms and safety regulations can threaten life and limb of the operator. Irrespective of whether our chucks are used under rotation or stationary, it is mandatory to wear protective equipment in accordance with the EC machine guideline, so that loose parts, discharged in case of the chuck or a component malfunctioning, are absorbed by the protective equipment. The machine manufacturer must ensure that there is a sufficient wall thickness of its housing / protection equipment (considering the currently valid directives and standards), because this may cause a threat to the life and limb of the operator in the case of a fracture in the chuck jaws, or when the workpiece gets lost.

### CAUTION!

**Please observe all appropriate safety measures during the transportation and handling of any chucks of considerable weight.**



Recommended threshold values when lifting and carrying loads				
	Reasonable load in kg and frequency of lifting and carrying			
	Occasionally		More frequently	
Age in years	Women	Men	Women	Men
15 - 18	15	35	10	20
19 - 45	15	55	10	30
above 45	15	45	10	25

### DANGER!

**Regularly check the clamping force by inserting a power meter in the lathe chuck.**



**CAUTION!**

Risk of damages due to incorrect choice of clamping position for chuck jaws on workpiece. If an incorrect clamping position is chosen for the chuck jaws on workpiece, the lathe chuck jaws may be damaged. The external diameter of jaws must not exceed the external diameter of the chuck by more than max. 10%.

**CAUTION!**

Hazard from vibration due to imbalanced rotating parts and noise generation. Physical and mental strains due to imbalanced workpieces and noise during the machining process on the clamped and rotating workpiece.



- Ensure the chuck's axial and concentric runout.
- Check options for remedying imbalances on workpieces.
- Reduce the speed.
- Wear hearing protection.
- If the chuck is involved in a collision, it must be subjected to a crack test before using it again.

**4.25.2 Basic safety instructions**

- The permissible speed (as per VDI 3106) must be calculated for the machining allowance; the maximum guide speed must not be exceeded. The calculated values must be tested by performing a dynamic measurement.
- The max. guide speed may only be applied with max. introduced actuation force and a chuck that is in perfect working condition.
- If the chuck is involved in a collision, it must be subjected to a crack test before using it again. Damaged parts must be replaced using original spare parts.
- The chuck may only be mounted and removed, commissioned, operated and maintained by authorised and skilled staff following safety training.
- We recommend checking the clamping force before starting a new series batch and between maintenance intervals with a clamping force measuring device. Only regular checks guarantee best possible safety.

**4.25.3 Optional soft lathe chuck jaws****CAUTION!**

The optionally available soft chuck jaws are jaws, which must be stepped according to the application. Unstepped jaws lead to an increased centrifugal torque with a reduced permissible rotational speed of the rotary chuck.





## 4.25.4 Calculating the required clamping force for a given speed

The initial clamping force  $F_{sp0}$  is the total force impacting radially on the workpiece via the jaws due to actuation of the lathe chuck during shutdown. Under the influence of rpm, the jaw mass generates an additional centrifugal force. The centrifugal force reduces or increases the initial clamping force depending on whether gripping takes place from the outside in or from the inside out. The sum of the initial clamping force  $F_{sp0}$  and the centrifugal force  $F_c$ , is the effective clamping force  $F_{sp}$ .

$$F_{sp} = F_{sp0} \pm F_c \text{ [N]}$$

- for gripping from the outside in  
+ for gripping from the inside out

Legend			
$F_c$	Total centrifugal force [ N ]	$M_{cAB}$	Centrifugal force of top jaws in [ kgm ]
$F_{sp}$	Effective clamping force [ N ]	$M_{cGB}$	Centrifugal force of base jaws in [ kgm ]
$F_{spmin}$	Required static clamping force [ N ]	n	Rotational speed [ rpm ]
$F_{sp0}$	Initial clamping force [ N ]	$r_s$	Center of gravity radius [ mm ]
$F_{spz}$	Cutting force [ N ]	$r_{sAB}$	Center of gravity radius of top jaw
$m_{AB}$	Mass of one top jaw [ kg ]	$s_{sp}$	Clamping force safety factor
$m_B$	Mass of chuck jaw set [ kg ]	$s_z$	Safety factor for cutting
$M_c$	Centrifugal force torque [ kgm ]	$\Sigma_s$	Max. Clamping force of the chuck [ KN ]
1 Newton (N) = 1 kg m/s <sup>2</sup>			

### DANGER!

Risk to life and limb of the operating personnel and significant property damage when the RPM limit is exceeded! With gripping from the outside inwards, and with increasing RPM, the effective clamping force is reduced by the magnitude of the increasing centrifugal force (the forces are opposed). When the RPM limit is exceeded, the clamping force drops below the minimum clamping force  $F_{spmin}$ . Consequently, the workpiece is released in an unchecked manner.



- Do not exceed the calculated RPM.
- Do not fall below the necessary minimum clamping force.



#### 4.25.5 Clamping force-speed diagram - Lathe chuck K11-160

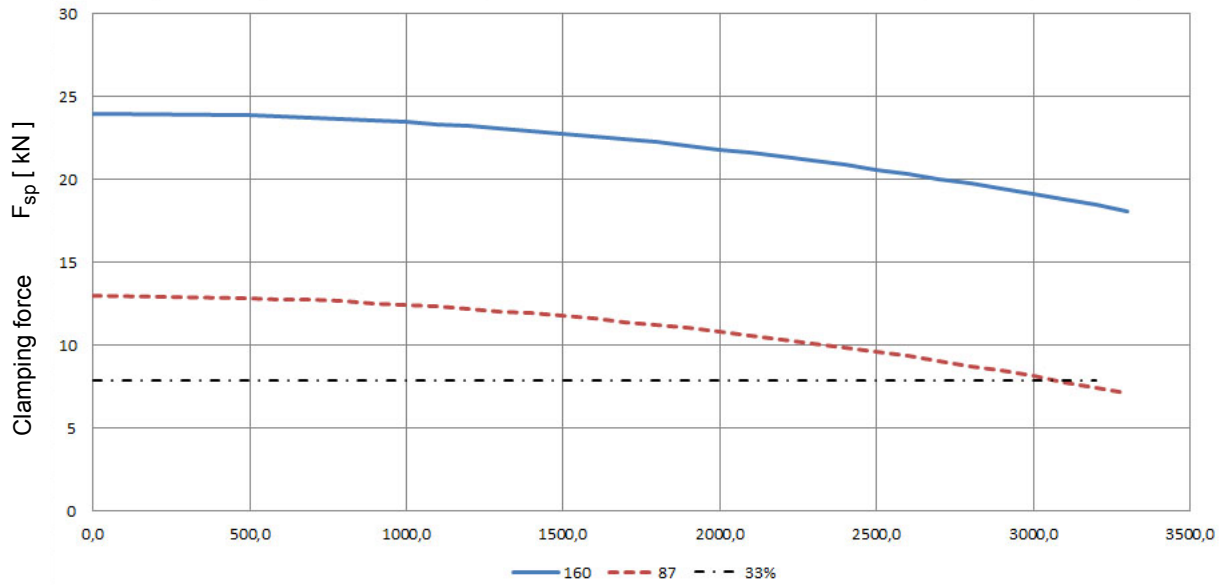

Speed n [rpm]

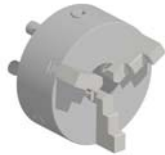

- — — Required minimum clamping force 33 %
- - - Tightening torque with key 87 Nm
- Tightening torque with key max. 160 Nm

The clamping force to speed diagram shows the calculated centrifugal force with the matching jaw design as a function for the speed if the chuck jaws do not protrude beyond the outer diameter of the chuck.

#### 4.25.6 Clamping jaw centrifugal force

To calculate the required tensioning force for processing a workpiece, the centrifugal force of the clamping jaws must be taken into account.

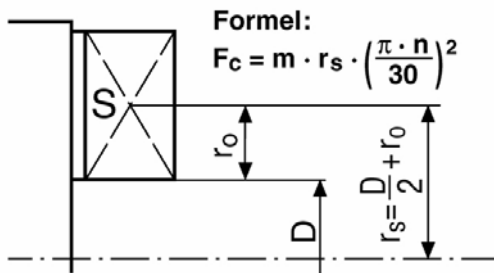

F <sub>c</sub>	Centrifugal force in N
m	Mass in kg/set
r <sub>s</sub>	Centre of gravity distance to the centre of the chuck in metres
n	Speed min <sup>-1</sup>
r <sub>0</sub>	Centre of gravity distance to the clamping jaw

The permissible speeds can be determined in accordance with VDI Guideline 3106 "Determining the permissible speed for lathe chucks (jaw chucks). This guideline also allows for the residual tensioning force at a specified speed to be determined.

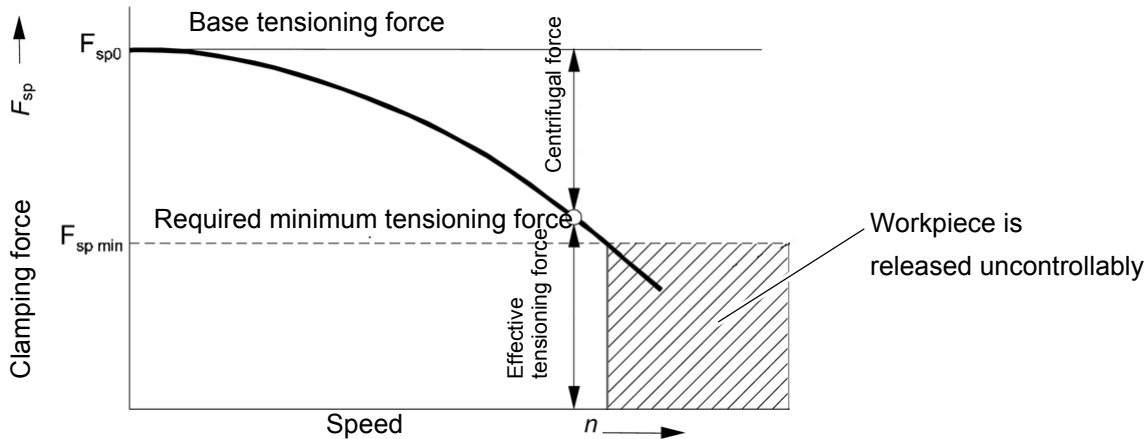

The required effective clamping force for machining  $F_{sp}$  is calculated from the product of the machining force  $F_{spz}$  with the safety factor  $S_z$ . This factor takes into account uncertainties in the calculation of the clamping force.

According to VDI 3106, the following also applies here:

$$F_{sp} = F_{spz} \cdot S_z \text{ [ N ]}$$

From this we can derive the calculation of the initial clamping force during shutdown:

$$F_{sp0} = S_{sp} \cdot (F_{sp} \pm F_c) \text{ [ N ]}$$

- for gripping from the outside in  
+ for gripping from the inside out

### ATTENTION!

**This calculated force must not be larger than the maximum clamping force  $\Sigma S$  ( 24 kN ) engraved on the chuck.**



From the above formula it is evident that the sum of the effective clamping force  $F_{sp}$  and the total centrifugal force  $F_c$  is multiplied by the safety factor for the clamping force  $S_{sp}$ .

According to VDI 3106, the following also applies here:  $S_{sp} \geq 1.5$

The total centrifugal force  $F_c$  is dependent both on the sum of the masses of all jaws and on the center of gravity radius and the RPM.

### ATTENTION!

**For safety reasons, in accordance with DIN EN 1550, the centrifugal force may be a maximum of 67% of the initial clamping force.**



The formula for the calculation of the total centrifugal force  $F_c$  is:

$$F_c = \sum (m_b \cdot r_s) \cdot \left( \frac{\pi \cdot n}{30} \right)^2 = \sum M_c \cdot \left( \frac{\pi \cdot n}{30} \right)^2 \text{ [ N ]}$$

$n$  is the given speed in r.p.m.. The product  $m_B \cdot r_s$  is described as the centrifugal force torque  $M_c$ .

$$M_c = m_B \cdot r_s \text{ [ kgm ]}$$





In case of chucks with split chuck jaws, i.e. with base jaws and top jaws, for which the base jaws change their radial position only by the stroke amount, the centrifugal torque of base jaws  $M_{cGB}$  and the centrifugal torque of top jaws  $M_{cAB}$  need to be added:

$$M_c = M_{cGB} + M_{cAB} \text{ [ kgm ]}$$

The centrifugal torque of the base jaws  $M_{cGB}$  can be found in the data of the lathe chuck.

The centrifugal torque of the top jaws  $M_{cAB}$  is calculated.

$$M_{cAB} = m_{AB} \cdot r_{sAB} \text{ [ kgm ]}$$

The lathe chuck K11-160 has no base jaws and no top jaws.

#### Example:

- The centre of gravity radius  $r_s$  of the jaw = 0.05160 m (jaw flush with the outer diameter of the chuck)
- Weight of a jaw = 0.318kg
- Centrifugal moment for one jaw

$$M_c = 0.318 \text{ kg} \cdot 0.05160 \text{ m} = 0.0164 \text{ kgm}$$

- The lathe chuck has 3 jaws.

$$= 0.0164 \text{ kgm} \cdot 3 = 0.0492 \text{ kgm}$$

- Calculation of the total centrifugal force at a rotational speed of 3000 rpm

$$F_c = \sum (m_b \cdot r_s) \cdot \left( \frac{\pi \cdot n}{30} \right)^2 = \sum M_c \cdot \left( \frac{\pi \cdot n}{30} \right)^2 \text{ [N]}$$

$$= 0.0492 \text{ kgm} \cdot \left( \frac{3.14 \cdot 3000}{30} \right)^2 = 4850.9 \text{ N} = 4.8 \text{ kN}$$

The total possible clamping force of the chuck at a standstill is  $\sum_s 24 \text{ kN}$  at a tightening torque of 160 Nm with the lathe chuck key.

An effective clamping force  $F_{sp}$  of 19.2 kN remains at the chuck.

$$F_{sp} = \sum_s - F_c = 24 \text{ kN} - 4.8 \text{ kN} = \mathbf{19.2 \text{ kN}}$$

see Clamping force-speed diagram - Lathe chuck K11-160 on page 63

see Basic safety instructions on page 61

#### WARNING!

The greater distance above the chuck surface that clamping occurs, the lower the clamping force will be.



#### 4.25.7 Notes on instruction of operating personnel

We recommend that the business operating our manual chucks makes the operating instructions in particular this section "Safety" available to all persons being in charge of operation, maintenance and repair, with the intention of acquiring specialised knowledge. We further recommend that the business operator issues internal "operating instructions" which take into account the known qualifications of the operating personnel.



The business operator must guarantee that suitable measures in organisation and instruction are taken to ensure that the appropriate safety rules and regulations are complied with by the persons entrusted with operation, maintenance and repair of the manual chuck.

## 4.25.8 Lubricating and cleaning the lathe chuck

### ATTENTION!

**Do not use compressed air to remove dust and foreign substances from the lathe chuck.**

Coolant squirts on the lathe chuck and removes the grease from the master jaws. In order to maintain the tensioning force and the long-term accuracy of the lathe chuck, the lathe chuck must be lubricated regularly. Insufficient lubrication will result in malfunctions at reduced tensioning force, which affects the accuracy and causes excessive wear and seizing.

Depending on the chuck type and operating state, the tensioning force of a lathe chuck can decrease by up to 50 percent of the nominal tensioning force.

A presumably securely clamped workpiece can then fall out of the chuck during processing.

Oil the chuck regularly at the oiler. Use additional an lubricant on the toothing of the clamping jaws, which is of high quality and for high pressure bearing surfaces. The lubricant should withstand the coolant and other chemicals.



MACHINERYHOUSE



## 5 Maintenance

In this chapter you will find important information about

- Inspection
- Maintenance
- Repair

of the lathe.

### ATTENTION!

Properly performed regular maintenance is an essential prerequisite for

- operational safety,
- failure-free operation,
- long durability of the lathe and
- the quality of the products which you manufacture.



Installations and equipment from other manufacturers must also be in good order and condition.

### 5.1 Safety

#### WARNING!

The consequences of incorrect maintenance and repair work may include:

- extremely serious injuries to those working on the lathe and
- damage to the lathe.



Only qualified personnel should carry out maintenance and repair work on the lathe.

Electrical systems and operating materials may only be installed, modified and repaired by a trained electrician or supervised and under the control of a trained electrician and must comply with electrotechnical regulations.

#### WARNING!

Do not climb onto or into the machine while working.



#### 5.1.1 Preparation

##### WARNING!

Only carry out work on the lathe, if the main switch is switched off and secured against restarting by means of a padlock.

☞ Disconnecting and securing the lathe on page 15

Attach a warning sign.



#### 5.1.2 Restarting

Before restarting, run a safety check.

☞ Electronics on page 15

☞ Safety check on page 13

##### WARNING!

Before starting the lathe, you must check that there is no danger for persons and that the lathe is not damaged.





## 5.1.3 Cleaning

### CAUTION!

Use a chip hook for removal of chips and wear suitable protective gloves.



## 5.2 Check up, inspection and maintenance



The type and level of wear depends to a large extent on the individual usage and operating conditions. Any indicated intervals therefore are only valid for the corresponding approved conditions.

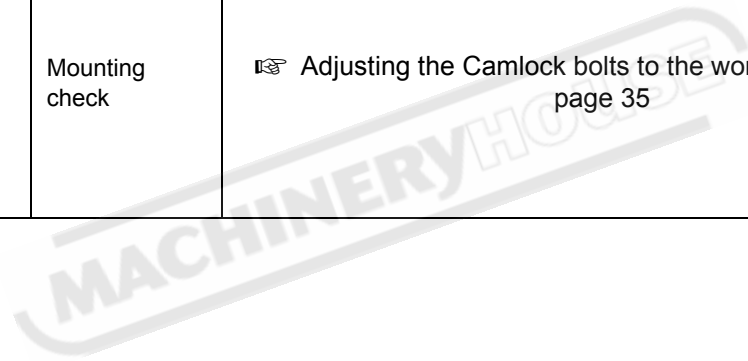

Interval	Where?	What?	How?
Start of work, after every maintenance or repair work	Lathe		☞ Safety check on page 13
	Lathe	Oiling	<ul style="list-style-type: none"> <li>➔ Oil all guide rails.</li> <li>➔ Lubricate the change gears lightly with lithium-based grease lubricating</li> </ul>
	Camlock clamp bolt Lathe spindle fixture	Mounting check	☞ Adjusting the Camlock bolts to the workpiece holder on page 35



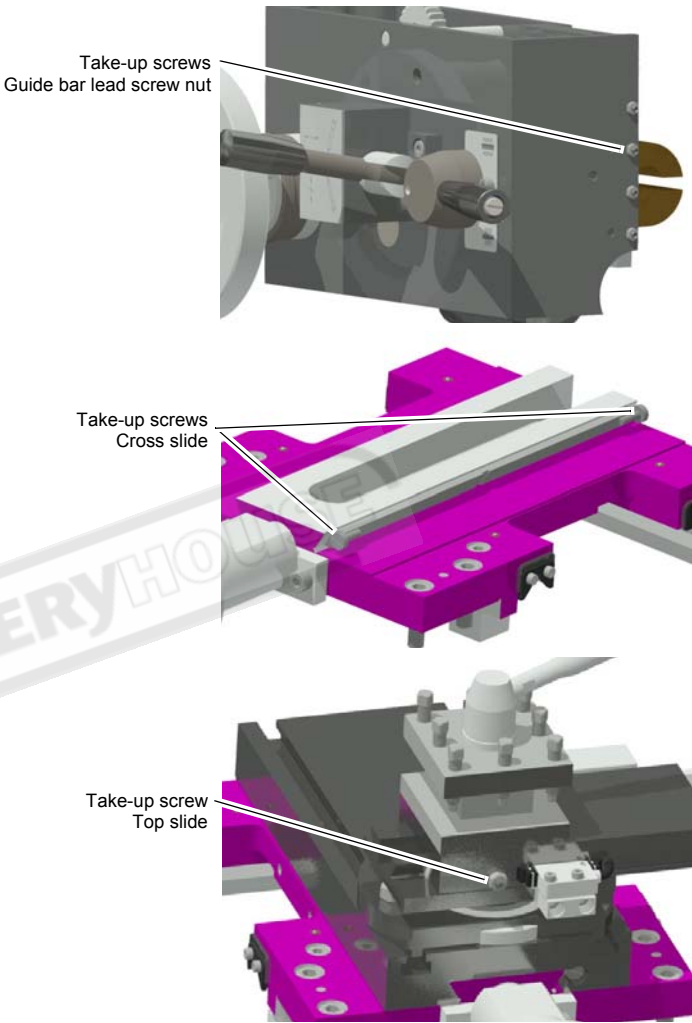



Interval	Where?	What?	How?
<p>When necessary</p>	<p>Slideways</p>	<p>Readjust</p>	<p>Excessive clearance in the slideways can be reduced by readjusting.</p> <p>➔ Turn the take-up screw clockwise. The gib is moved to the rear and reduces the clearance of the corresponding slideway.</p>  <p style="text-align: right;">Img.5-1: Take-up screws slideways</p>
<p>Start of work, after every maintenance or repair work</p>	<p>Speed gear unit</p>	<p>Visual inspection</p>	<ul style="list-style-type: none"> <li>➔ Check the oil level in the inspection glass</li> <li>○ of the speed gear unit  Img.5-2: auf Seite 70</li> <li>➔ The oil level must at least attain the centre resp. top marking of the oil sight glass.</li> <li> Operating material on page 17.</li> </ul>

TU3008G\_GB\_5.fm

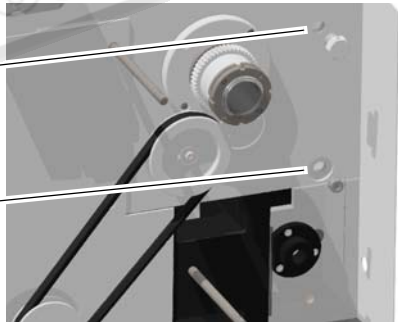

Interval	Where?	What?	How?
<b>Start of work, after every maintenance or repair work</b>	<b>Feed gear</b>	Visual inspection	<ul style="list-style-type: none"> <li>➔ Check the oil level in the inspection glass</li> <li>○ of the feed gear  Img.5-3: auf Seite 71</li> <li>➔ The oil level must at least attain the centre resp. top marking of the oil sight glass.</li> <li> Operating material on page 17.</li> </ul>
<b>First after 200 hours in service, then once a year</b>	<b>Speed gear unit</b>	Oil change	<ul style="list-style-type: none"> <li>➔ For oil change use an appropriate collecting container with sufficient capacity.</li> <li>➔ Unscrew the screw from the drain hole.</li> <li>➔ Unscrew the screw from the filler hole.</li> <li>➔ Close the drain hole if no more oil drains.</li> <li>➔ Fill up to the middle of the reference mark of the oil sight glass into the filler hole using a suitable container.</li> <li> Operating material on page 17</li> </ul> <div style="text-align: right; margin-top: 10px;">  <p>Filler hole</p> <p>Outlet</p> </div> <div style="text-align: right; margin-top: 10px;">  <p>Oil sight glass</p> </div> <p style="text-align: right; margin-top: 10px;">Img.5-2: Speed gear unit</p>

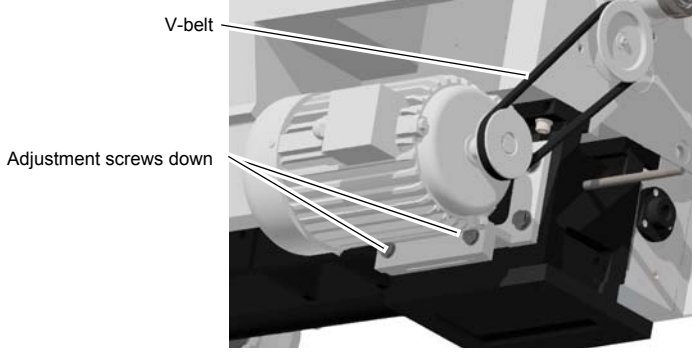

Interval	Where?	What?	How?
<p>First after 200 hours in service, then once a year</p>	<p>Feed gear</p>	<p>Oil change</p>	<ul style="list-style-type: none"> <li>➔ For oil change use an appropriate collecting container with sufficient capacity.</li> <li>➔ Unscrew the screw from the drain hole.</li> <li>➔ Unscrew the screw from the filler hole.</li> <li>➔ Close the drain hole if no more oil drains.</li> <li>➔ Fill up to the middle of the reference mark of the oil sight glass into the filler hole using a suitable container.  Operating material on page 17</li> </ul> <div style="text-align: right;">  <p>Img.5-3: Feed gear</p> </div>
<p>When necessary</p>	<p>Headstock</p>	<p>V-belt check, re-tighten</p>	<ul style="list-style-type: none"> <li>➔ Tighten the V-belt set as required.</li> <li>➔ Loosen the screws of the motor plate.</li> <li>➔ Tense the V-belt with the adjustment screws in a way that it can still be pressed down approximately 3 mm with the forefinger.</li> </ul> <div style="text-align: right;">  <p>Img.5-4: V-belt</p> </div>

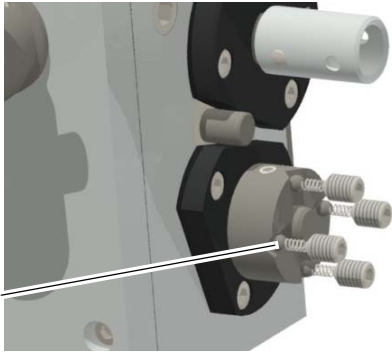
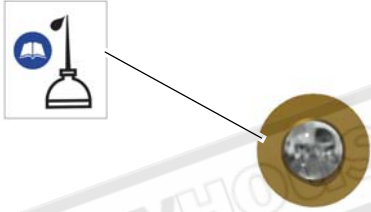
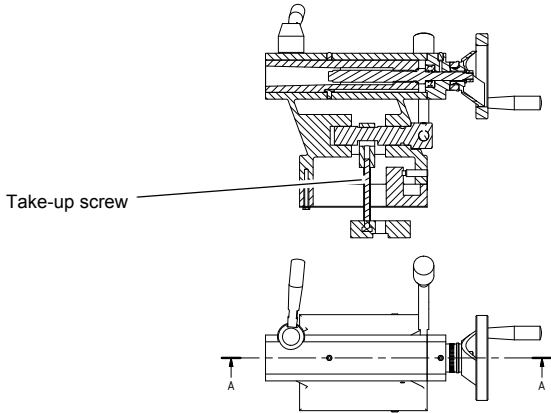

Interval	Where?	What?	How?
When necessary	Feed rod	Function control	 <p>Clutch feed rod</p> <p>Img.5-5: Clutch feed rod</p>
Weekly	Lead screw, feed rod, tailstock, Cross slide, top slide, Lathe saddle, headstock, Change gear	Oiling	<p>➔ Lubricate or fill all oilers with machine oil; do not use a grease gun or similar equipment. Use the oil bottle in the delivery volume.</p>  <p>Oiler cup</p> <p>Img.5-6: Oiler cup</p>
When necessary	Tailstock	tighten	<p>➔ If the tailstock clamping wears off. Shorten the tension way with the take-up screw.</p>  <p>Take-up screw</p> <p>Img.5-7: Tailstock</p>
Weekly	Lathe chuck	Lubricating	<p>☞ Lubricating and cleaning the lathe chuck on page 66</p>



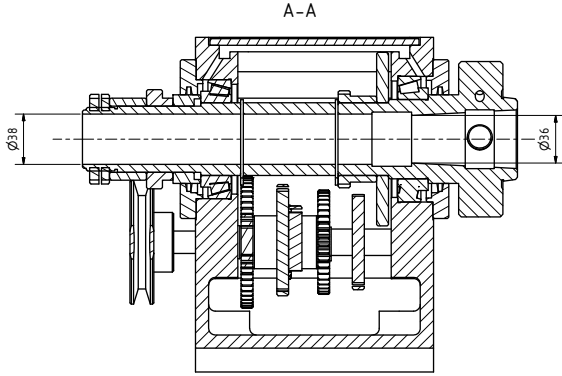
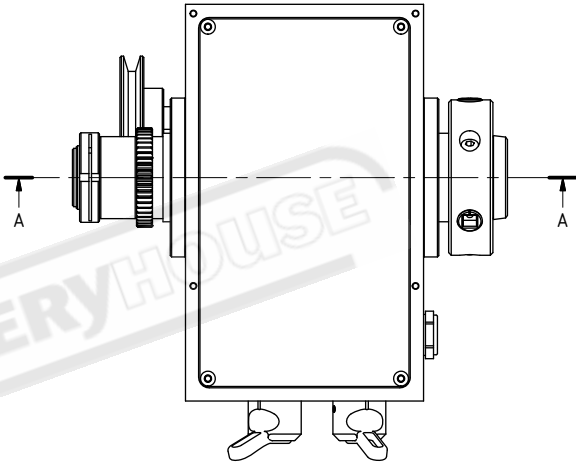
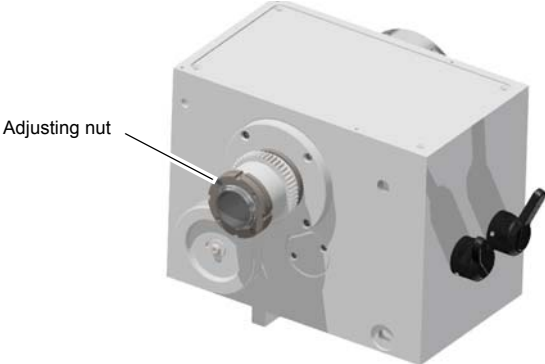

Interval	Where?	What?	How?
<p>When necessary</p>	<p>Spindle bearing</p>	<p>tighten</p>	<p>→ If the initial tension of the tapered roller bearings decreases, retighten it with the adjusting nut.</p>   <p>Img.5-8: Spindle bearing</p>  <p>Adjusting nut</p> <p>Img.5-9: Adjusting nut</p>
<p>based on operator's empirical values if necessary in accordance with German DGUV (BGV A3)</p>	<p>Electronics</p>	<p>Electrical inspection</p>	<p>☞ Electronics on page 15</p>

TU3008G\_GB\_5.fm



Interval	Where?	What?	How?
after 4 years	Electronics	Replacing	<p>The service life off the direction of rotation switch (ZH-A) may have been reached due to the operating conditions. Replacement is recommended to ensure further, fault-free operation.</p> <p>By the service technicians</p> <p> Customer service technician on page 74</p>

## 5.3 Repair

### 5.3.1 Customer service technician

For any repair work request the assistance of an authorised customer service technician. Contact your specialist dealer if you do not have customer service's information or contact Hare & Forbes Machineryhouse who can provide you with a specialist dealer's contact information. Optionally, the

Hare & Forbes Machineryhouse

[www.machineryhouse.com.au](http://www.machineryhouse.com.au)

[www.machineryhouse.co.nz](http://www.machineryhouse.co.nz)

can provide a customer service technician, however, the request for a customer service technician can only be made via your specialist dealer.

If repairs are performed by other qualified technical personnel, they must follow the instructions in this operation manual.

Optimum Maschinen Germany GmbH accepts no liability nor does it guarantee against damage and operating malfunctions resulting from failure to observe these operating instructions.

For repairs, only use

- faultless and suitable tools,
- original parts or parts from series expressly authorised by Optimum Maschinen Germany GmbH.

## 6 Ersatzteile - Spare parts

### 6.1 Ersatzteilbestellung - Ordering spare parts

Bitte geben Sie folgendes an - Please indicate the following :

- Seriennummer - Serial No.
- Maschinenbezeichnung - Machines name
- Herstellungsdatum - Date of manufacture
- Artikelnummer - Article no.

Die Artikelnummer befindet sich in der Ersatzteilliste. *The article no. is located in the spare parts list.* Die Seriennummer befindet sich am Typschild. *The serial no. is on the rating plate.*

### 6.2 Hotline Ersatzteile - Spare parts Hotline



Australian Distributor  
sales@machineryhouse.com.au



New Zealand Distributor  
sales@machineryhouse.co.nz



### 6.3 Service Hotline



Australian Distributor  
service@machineryhouse.com.au



New Zealand Distributor  
service@machineryhouse.co.nz



## 6.4 Ersatzteilzeichnungen - Spare part drawings

### A Spindelstock - Headstock

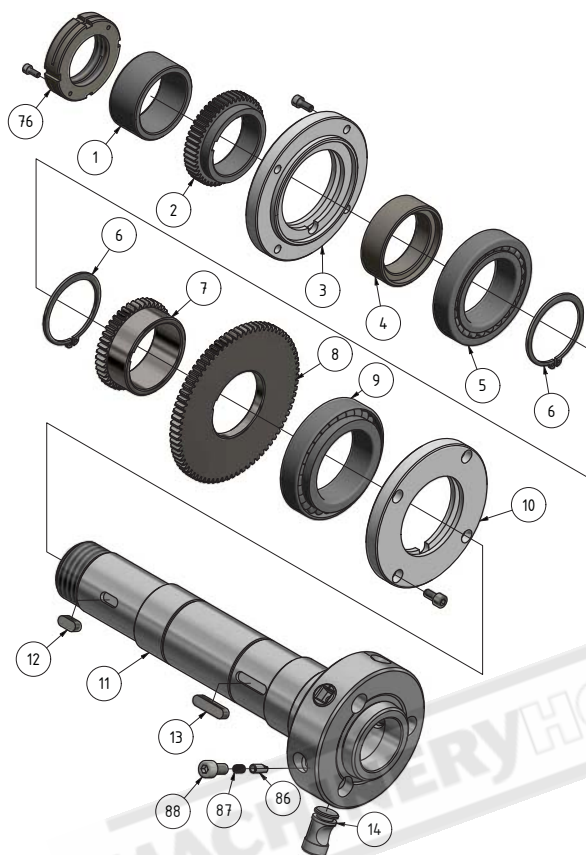

### B Spindelstock - Headstock



Abb.6-1: Spindelstock - Headstock

**C Spindelstock - Headstock, Version 1.0**

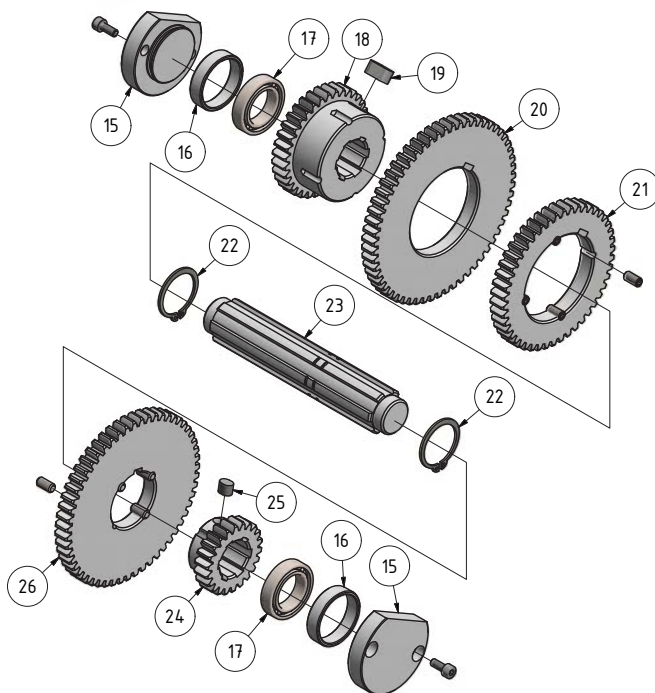

Abb.6-2: Spindelstock - Headstock

**D Spindelstock - Headstock, Version 1.1**

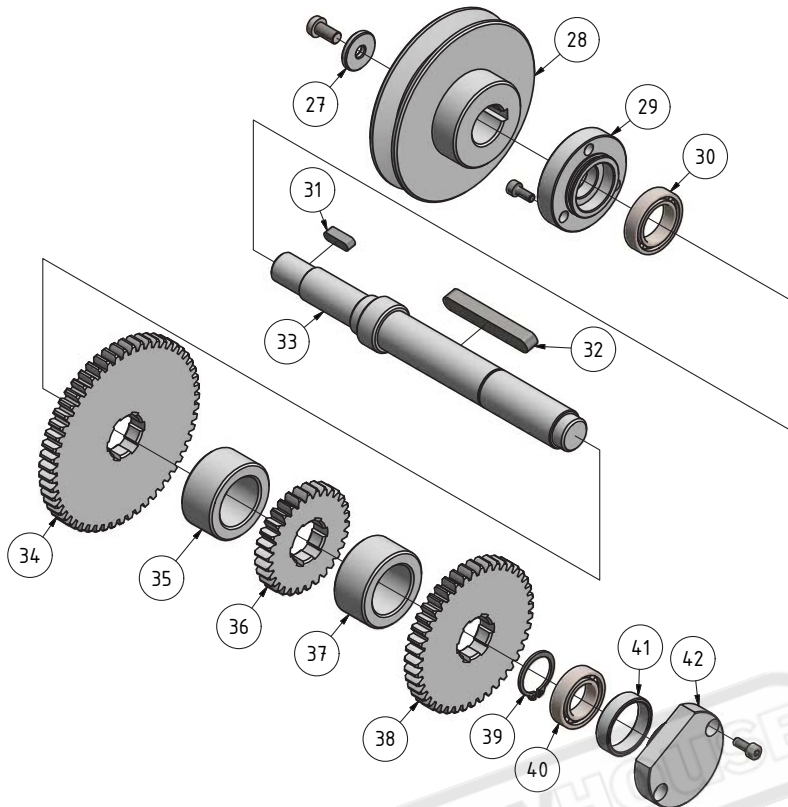

Abb.6-3: Spindelstock - Headstock

TU3008G\_parts.fm

## E Spindelstock - Headstock

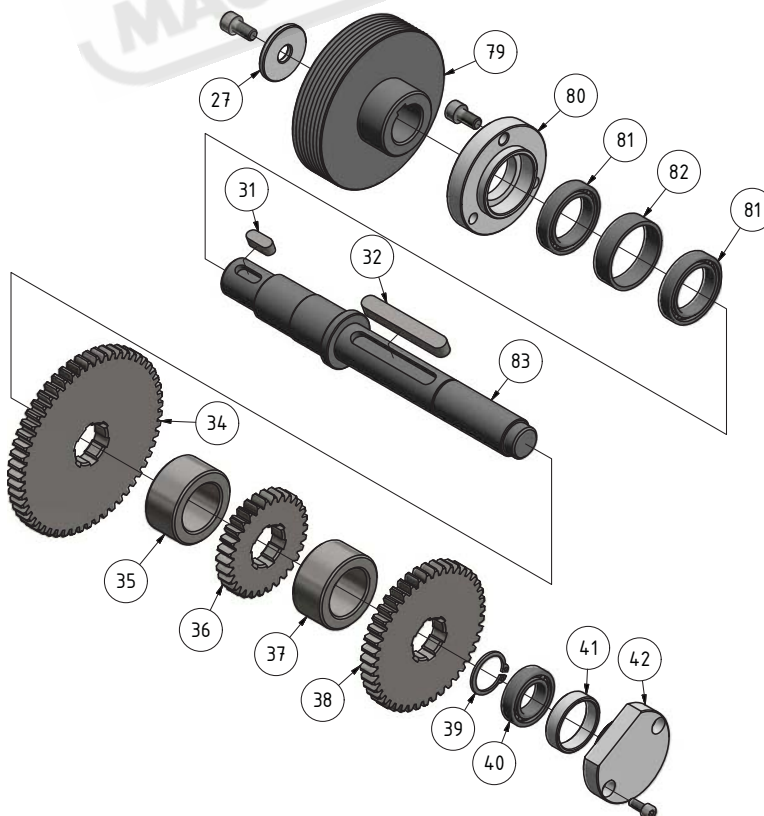

Abb.6-4: Spindelstock - Headstock

## F Spindelstock - Headstock

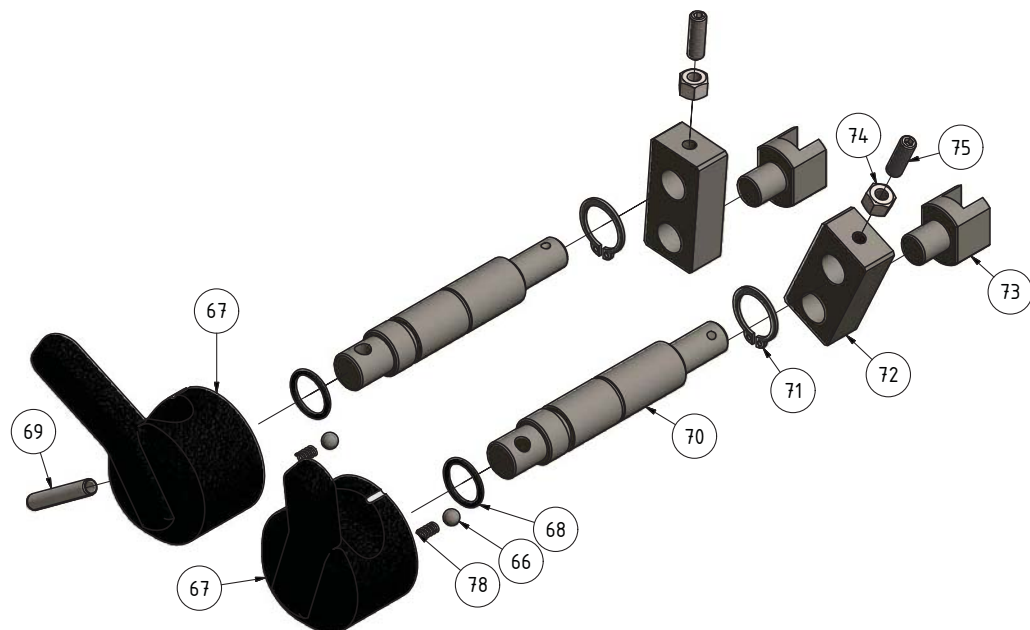

Abb.6-5: Spindelstock - Headstock

TU3008G\_parts.fm

TU3008G - Teilleiste Spindelstock - Headstock parts list					
Pos.	Bezeichnung	Description	Menge	Grösse	Artikelnummer
			Qty.	Size	Item no.
1	Ring	Ring	1		03427210101
2	Zahnrad	Gear	1		03427210102
3	Flansch	Flange	1		03427210103
4	Ring	Ring	1		03427210104
5	Kegelrollenlager	Taper roller bearing	1	32011	04032011
6	Sicherungsring	Retaining ring	2	55x2	
7	Zahnrad	Gear	1		03427210107
8	Zahnrad	Gear	1		03427210108
9	Kegelrollenlager	Taper roller bearing	1	32012	04032012
10	Flansch	Flange	1		03427210110
11	Spindel	Spindle	1		03427210111
12	Passfeder	Fitting key	1	8x7x18	
13	Passfeder	Fitting key	1	8x7x32	03427210113
14	Spindelbolzen	Spindle bolt	3		03400923138
15	Flansch	Flange	2		03427210115
16	Ring	Ring	2		03427210116
17	Kugellager	Ball bearing	2	61804	04061804.2R
18	Zahnrad	Gear	1		03427210118
19	Passfeder	Fitting key	1	8x7x18	
20	Zahnrad	Gear	1		03427210120
21	Zahnrad	Gear	1		03427210121
22	Sicherungsring	Retaining ring	2	25x1,2	
23	Zahnwelle	Gear shaft	1		03427210123
24	Zahnrad	Gear	1		03427210124
25	Passfeder	Fitting key	1	6x6x14	
26	Zahnrad	Gear	1		03427210126
27	Scheibe	Washer	1		03427210127
28	Riemenscheibe	Pulley	1		03427210128
29	Flansch	Flange	1		03427210129
30	Kugellager	Ball bearing	1	61804	03427210130
31	Passfeder	Fitting key	1	5x5x16	
32	Passfeder	Fitting key	1	8x7x56	
33	Welle	Shaft	1		03427210133
34	Zahnrad	Gear	1		03427210134
35	Buchse	Bushing	1		03427210135
36	Zahnrad	Gear	1		03427210136
37	Buchse	Bushing	1		03427210137
38	Zahnrad	Gear	1		03427210138
39	Sicherungsring	Retaining ring	1	20x1,2	
40	Kugellager	Ball bearing	1	61903	03427210140
41	Ring	Ring	1		03427210141
42	Flansch	Flange	1		03427210142
43	Riemenabdeckung	Belt cover	1		03427210143
44	Abdeckung	Cover	1		03427210144
45	Rändelschraube	Knurled screw	2		03427210145
46	Gewindebolzen	Bolt	2		03427210146
47	Abdeckung	Cover	1		03427210147
48	Verriegelungsschalter Schutzabdeckung	Interlock switch, protective cover change gears	1	QKS8	034272001S5
49	Motorschutzschalter mit Hauptschalter	Motor protection switch with main switch	1	MP03, single channel	034272001S1
	Motorschutzschalter mit Hauptschalter	Motor protection switch with main switch	1	Kedu, RB9, double channel	034272001S12K
50	Abdeckung	Cover	2		03427210150
51	Platte	Plate	1		03427210151
52	Platte	Plate	1		03427210152
53	Spindelstock	Headstock	1		03427210153
54	Belüftungsschraube Getriebe	Gearbox ventilation screw	1		03427210154
55	Ablassschraube	Drain screw	1		03427210155
56	Ölschauglass	Oil sight glass	1		03427210156
57	Antriebsmotor	Drive motor	1	400V	0342720011M3
58	Motorhalter	Motor holder	1		03427210158

TU3008G\_parts.fm

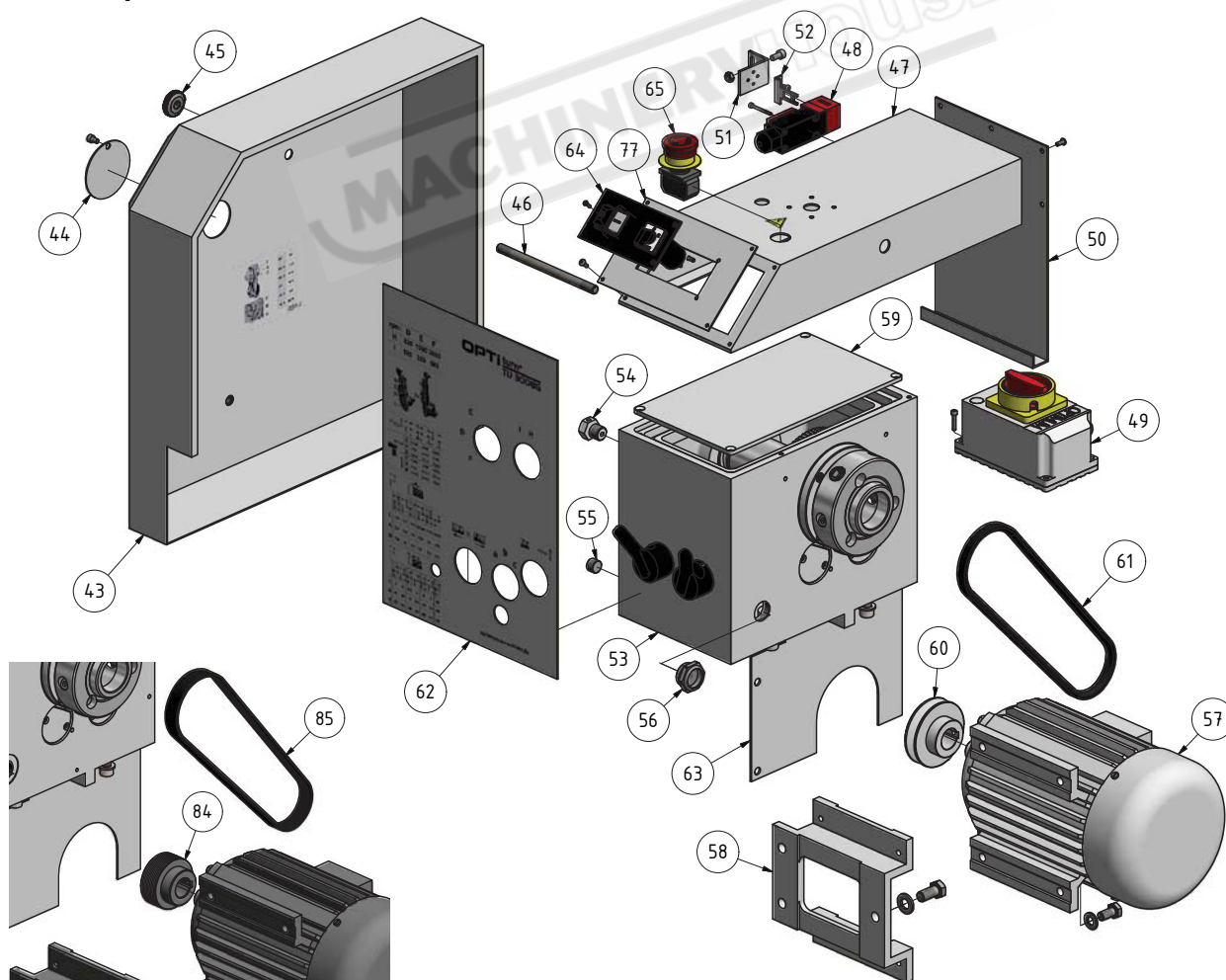
59	Abdeckung	Cover	1		03427210159
60	Riemenscheibe	Pulley	1		03427210160
61	Antriebsriemen	Drive belt	1	TRU-Power V13x735	03427210161
62	Abdeckung	Cover	1		03427210162
63	Abdeckung	Cover	1		03427210163
64	Schalterplatte (mit Ein-Aus Schalter und Drehrichtung)	Switch plate (with on-off switch and direction of rotation)	1		03427210164
65	Not-Halt Schalter	Emergency stop switch	1	HY57B	034272001S3
66	Stahlkugel	Steel ball	2		03427210166
67	Schalthebel	Switch lever	2		03427210167
68	O-Ring	O-Ring	2	12,5x1,8	
69	Federstift	Spring pin	2	5x45	
70	Welle	Shaft	2		03427210170
71	Sicherungsring	Retaining ring	2	15x1	
72	Platte	Plate	2		03427210172
73	Gabel	Fork	2		03427210173
74	Sechskantmutter	Hexagon nut	2	M5	
75	Gewindestift	Grub screw	2	M5x16	
76	Klemmmutter	Clamp nut	1		03427210176
77	Abdeckung	Cover	1		03427210177
78	Feder	Spring	2		03427210178
<b>Version 1.1 ab/from 2017</b>					
79	Riemenscheibe	Pulley	1		03427210179
80	Flansch	Flange	1		03427210180
81	Kugellager	Ball bearing	2	61805	04061805
82	Abstandring	Spacer	1		03427210182
83	Welle	Shaft	1		03427210183
84	Riemenscheibe	Pulley	1		03427210184
85	Antriebsriemen	Drive belt	1		03427210185
86	Sperraste	Stop bolt	3		03400923137
87	Feder	Spring	3		03400923136
88	Schraube	Screw	3	M6x16	03400923135



## G Wechselradgetriebe - Change gear



Abb.6-6: Wechselradgetriebe - Change gear

TU3008G - Wechselradgetriebe - Change gear					
Pos.	Bezeichnung	Description	Menge	Grösse	Artikelnummer
			Qty.	Size	Item no.
1	Halter	Holder	1		03427205201
2	Klemmmutter	Clamping nut	2		03427205202
3	Bolzen	Bolt	2		03427205203
4	Hülse	Sleeve	2		03427205204
5	Scheibe	Washer	2		03427205205
6	Scheibe	Washer	1		03427205206
7	Platte	Plate	2		03427205207
8	Zahnrad	Gear	1	75Z / m1.5	03427205208
9	Zahnrad	Gear	1	45Z / m1.5	03427205209
10	Zahnrad	Gear	1	80Z / m1.5	03427205210
11	Zahnrad	Gear	1	20Z / m1.5	03427205211
12	Zahnrad	Gear	1	85Z / m1.5	03427205212
13	Hülse	Sleeve	1		03427205204
14	Innensechskantschraube	Socket head screw	1	M8x45	
15	Schmiernippel	Lubrication cup	2		03427205215
17	Innensechskantschraube	Socket head screw	1	M6 x 16	
18	Zahnrad (ohne Abbildung)	Gear (not illustrated)	2	60Z / m1.5	03427205218
19	Zahnrad (ohne Abbildung)	Gear (not illustrated)	1	65Z / m1.5	03427205219
20	Zahnrad (ohne Abbildung)	Gear (not illustrated)	1	70Z / m1.5	03427205220
21	Zahnrad (ohne Abbildung)	Gear (not illustrated)	1	50Z / m1.5	03427205221
22	Zahnrad (ohne Abbildung)	Gear (not illustrated)	1	30Z / m1.5	03427205222
23	Hülse	Sleeve	1		03425001523

TU3008G\_parts.fm

## H Vorschubgetriebe - Feed gear

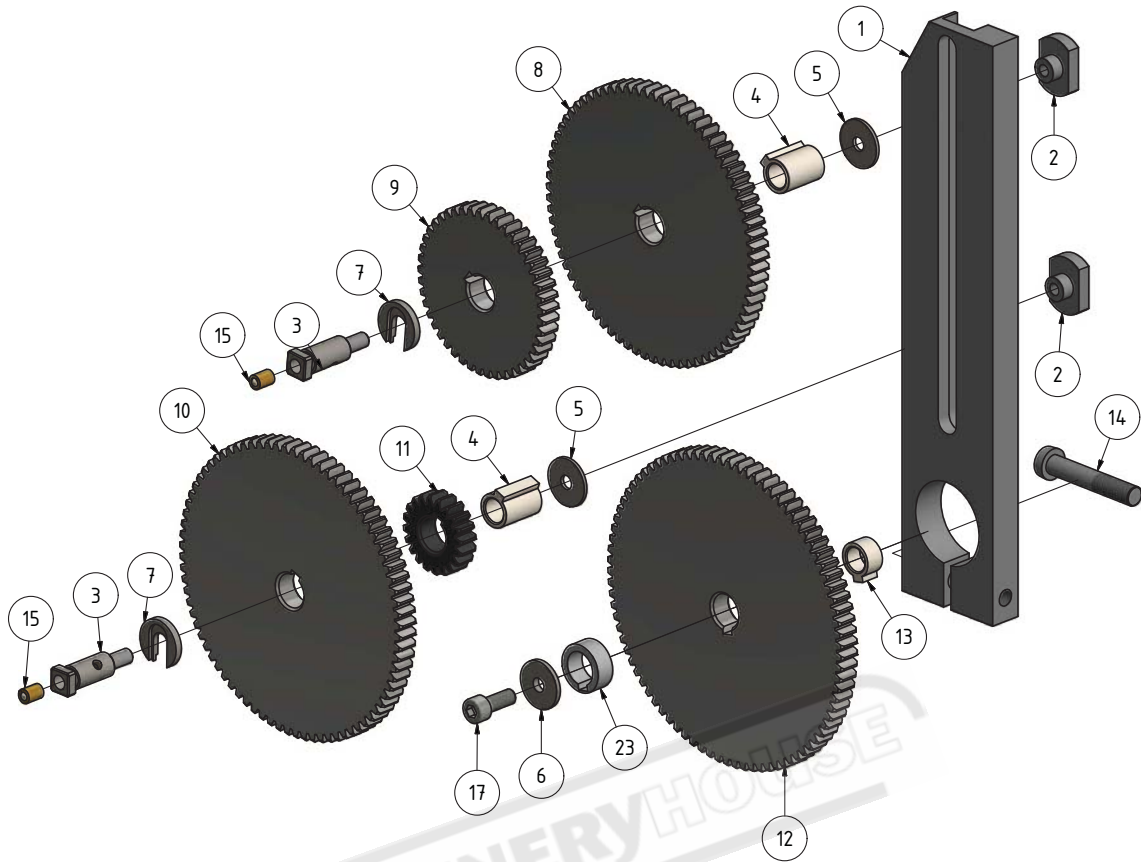

Abb.6-7: Vorschubgetriebe - Feed gear 1-2

**I      Vorschubgetriebe - Feed gear**

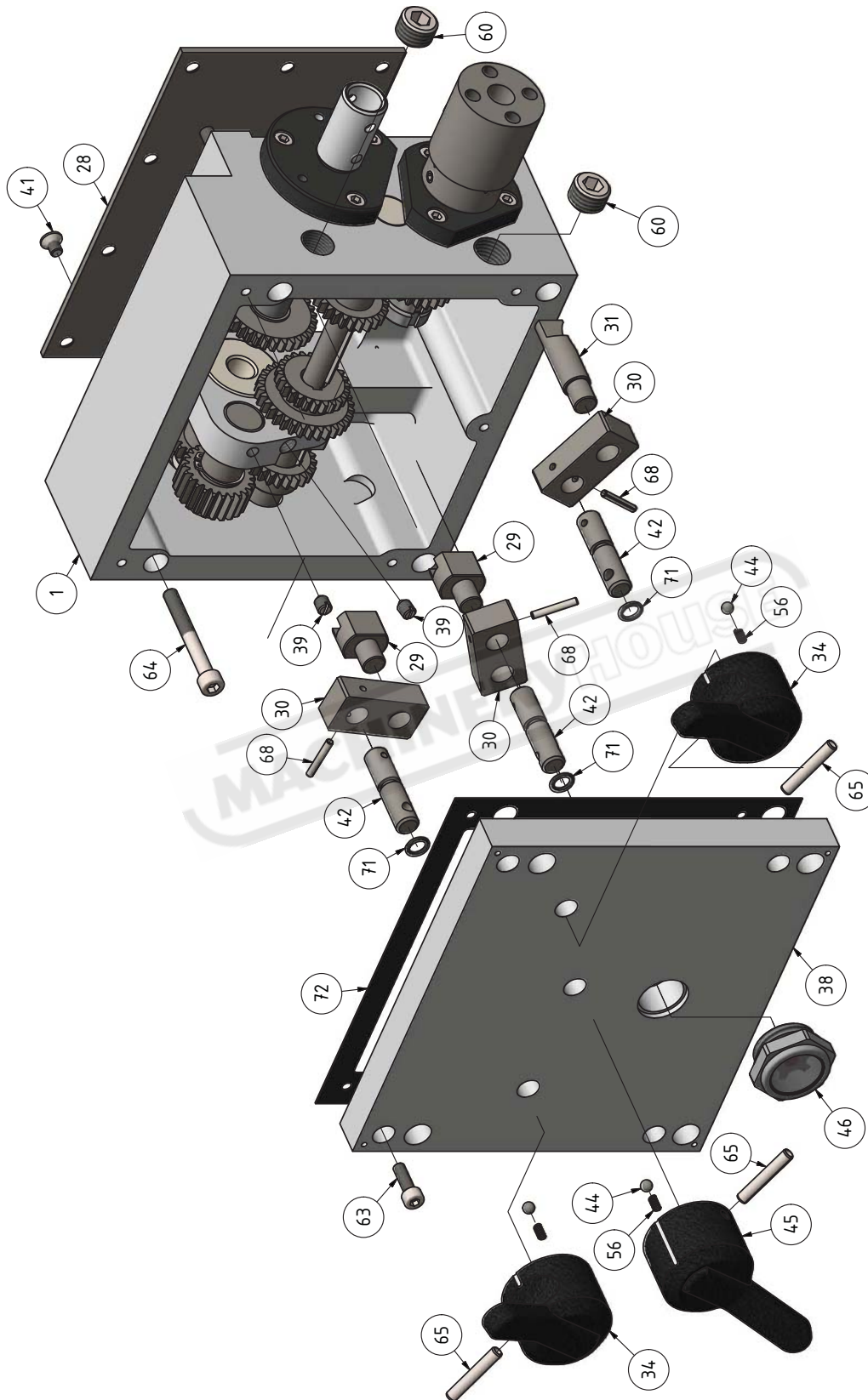

Abb.6-8: Vorschubgetriebe - Feed gear - 2-2

TU3008G\_parts.fm

TU3008G - Teilleiste Vorschubgetriebe - Feed gear parts list					
Pos.	Bezeichnung	Description	Menge	Grösse	Artikelnummer
			Qty.	Size	Item no.
1	Gehäuse	Housing	1		03427205301
2	Welle	Shaft	1		03427205302
3	Verschluss	Plug	1		03427205303
4	Verschluss	Plug	1		03427205304
5	O-Ring	O-ring	2	15x2,65	
6	Zahnrad	Gear	1		03427205306
7	Zahnrad	Gear	1		03427205307
8	Zahnrad	Gear	1		03427205308
9	Sicherungsring	Retaining ring	1	16	
10	Sicherungsring	Retaining ring	1	10	
11	Buchse	Bushing	1		03427205311
12	Passfeder	Fitting key	1	4x45	
13	Passfeder	Fitting key	1	4x16	
14	Zahnwelle	Gear shaft	1		03427205314
15	Welle	Shaft	1		03427205315
16	Zahnwelle	Gear shaft	1		03427205316
17	Kugellager	Ball bearing	2	6202	0406202.2R
18	Flansch	Flange	1		03427205318
19	Flansch	Flange	1		03427205319
20	Zahnrad	Gear	2		03427205320
21	Zahnrad	Gear	1		03427205321
22	Zahnrad	Gear	1		03427205322
23	Passfeder	Fitting key	1	4x22	
24	Passfeder	Fitting key	3	4x8	
25	Welle	Shaft	1		03427205325
26	Sicherungsring	Retaining ring	2	17	
27	O-Ring	O-ring	1	15x3,55	
28	Abdeckung	Cover	1		03427205328
29	Gabel	Fork	2		03427205329
30	Platte	Plate	3		03427205330
31	Bolzen	Bolt	1		03427205331
32	Kupplung	Clutch	1		03427205332
34	Schalthebel	Switch lever	2		03427210167
36	Rutschkupplung	Friction clutch	1		03427205336
37	Zahnrad	Gear	1		03427205337
38	Abdeckung	Cover	1		03427205338
39	Gewindestift	Grub screw	2	M6x8	
40	Innensechskantschraube	Socket head screw	9	M5x8	
41	Schraube	Screw	10	M5x8	
42	Welle	Shaft	3		03427205342
44	Stahlkugel	Steel ball	3		03427205344
45	Schalthebel	Switch lever	2		03427210344
46	Ölschauglas	Oil sight glass	1		03427205346
49	Ring	Ring	1		03427205349
50	Buchse	Bushing	1		03427205350
51	Kugellager	Ball bearing	2	7200	0407200
52	Ring	Ring	1		03427205352
53	Nutmutter	Groove nut	2	M10x1	
54	Welle	Shaft	1		03427205354
55	Ring	Ring	1		03427205355
56	Feder	Spring	1		03427205356
57	Stahlkugel	Steel ball	4	6mm	03427205357
58	Feder	Spring	4	1x4x23	03427205358
59	Gewindestift	Grub screw	1	M8x12	
60	Verschluss	Plug	2	M16x12	
61	Gewindestift	Grub screw	1	M6x12	
63	Innensechskantschraube	Socket head screw	4	M5x16	
64	Innensechskantschraube	Socket head screw	4	M6x50	
65	Spannstift	Spring pin	3	5x30	
66	Kegelstift	Taper pin	1	5x22	
67	Spannstift	Spring pin	1	5x32	
68	Spannstift	Spring pin	3	3x20	
70	Hülse	Sleeve	1		03427205370
71	O-Ring	O-ring	3	7,1x18,8	
72	Dichtung	Seal	1		03427205372
73	Sicherungsring	Retaining ring	1	15	

**J Schlosskasten - Apron**

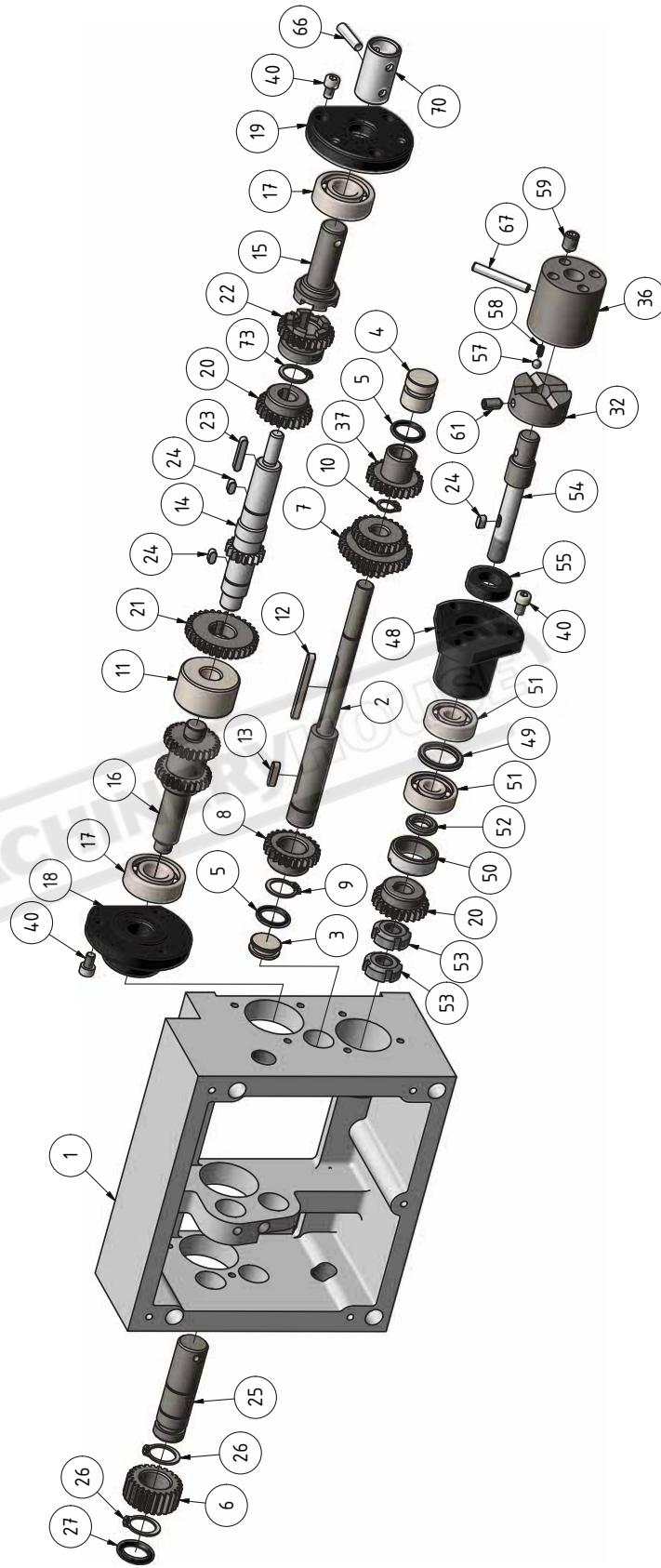
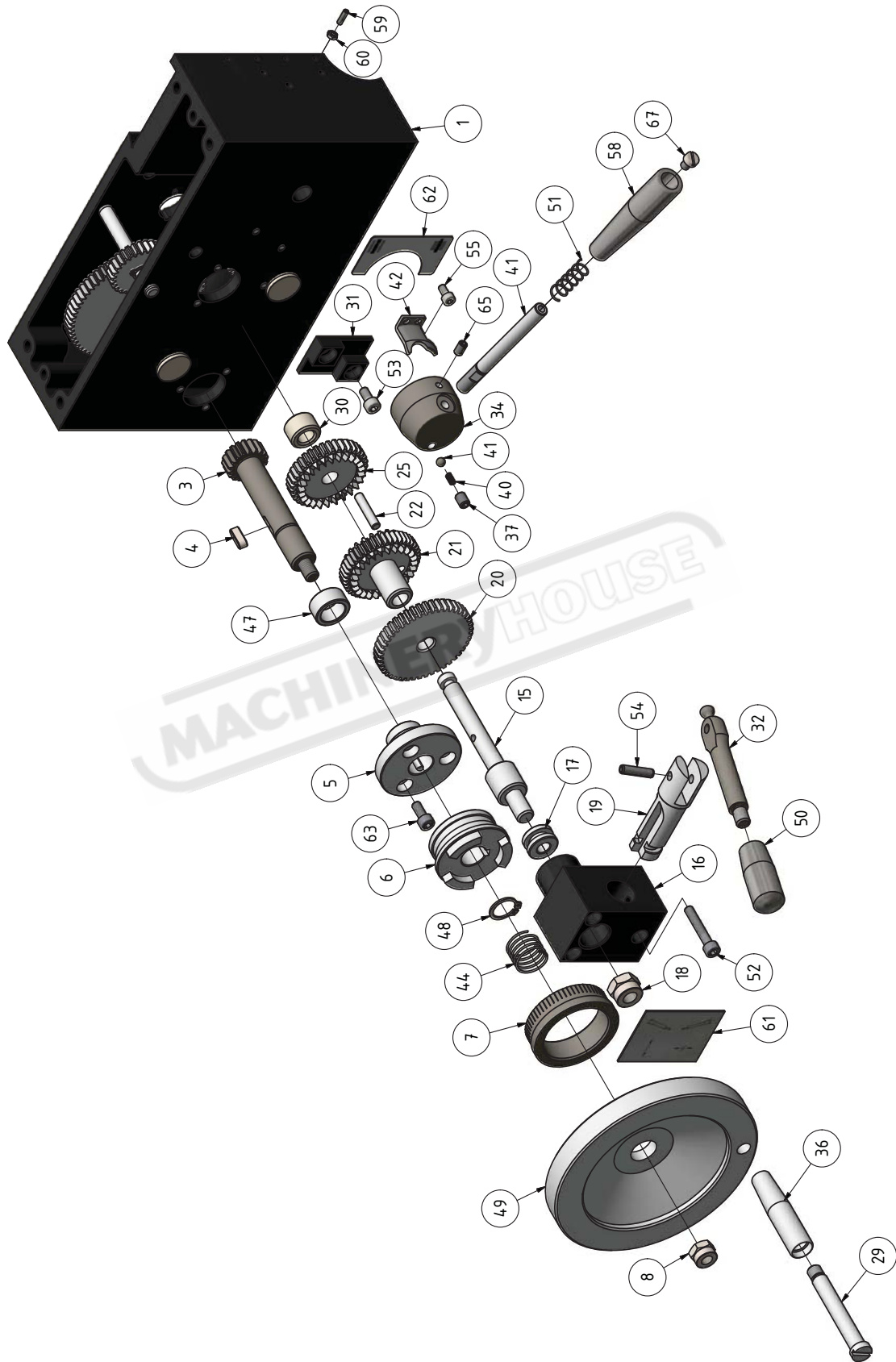

TU3008G\_parts.fm

Abb.6-9: Schlosskasten - Apron

## K Schlosskasten - Apron



Abb.6-10: Schlosskasten - Apron

TU3008G\_parts.fm

TU3008G - Teileliste Schlosskasten - Apron parts list					
Pos.	Bezeichnung	Description	Menge	Grösse	Artikelnummer
			Qty.	Size	Item no.
1	Gehäuse	Housing	1		03427205401
2	Welle	Shaft	1		03427205402
3	Zahnwelle	Gear shaft	1		03427205403
4	Passfeder	Fitting key	1	5x14	
5	Flansch	Flange	1		03427205405
6	Kupplung	Clutch	1		03427205406
7	Skalenring	Scale ring	1		03427205407
8	Sechskantmutter	Hexagon nut	1	M8	
9	Zahnwelle	Gear shaft	1		03427205409
10	Buchse	Bushing	2		03427205410
11	Buchse	Bushing	1		03427205411
12	Zahnrad	Gear	1		03427205412
13	Passfeder	Fitting key	1	5x10	
14	Zahnrad	Gear	1		03427205414
15	Welle	Shaft	1		03427205415
16	Block	Block	1		03427205416
17	Buchse	Bushing	1		
18	Sechskantmutter	Hexagon nut	1	M10x1,25	03427205418
19	Bolzen	Bolt	1		03427205419
20	Zahnrad	Gear	1		03427205420
21	Zahnrad	Gear	1		03427205421
22	Zylinderstift	Cylindrical pin	1		03427205422
23	Welle	Shaft	1		03427205423
24	Zahnrad	Gear	1		03427205424
25	Zahnrad	Gear	1		03427205425
26	Zahnrad	Gear	1		03427205426
27	Passfeder	Fitting key	2	4x14	
28	Buchse	Bushing	1		03427205428
29	Schraube	Screw	1		03427205429
30	Buchse	Bushing	1		03427205430
31	Platte	Plate	1		03427205431
32	Hebel	Lever	1		03427205432
33	Exzenter	Eccentric	1		03427205433
34	Nabe	Collet	1		03427205434
35	Platte	Plate	1		03427205435
36	Hülse	Sleeve	1		03427205436
37	Gewindestift	Grub screw	1		03427205437
38	Zylinderstift	Cylindrical pin	2	6x18	
39	Gewindestift	Grub screw	1	M6x16	
40	Feder	Spring	1	M6x8	
41	Stahlkugel	Steel ball	1		03427205441
42	Platte	Plate	1		03427205442
43	Zahnwelle	Gear shaft	1		03427205443
44	Feder	Spring	1		03427205444
45	Flansch	Flange	2		03427205445
46	Flansch	Flange	1		03427205446
47	Ring	Ring	1		03427205447
48	Sicherungsring	Retaining ring	1	15	
49	Handrad	Handle	1		03427205449
50	Knopf	Knob	1		03427205450
51	Feder	Spring	1		03427205451
52	Innensechskantschraube	Socket head screw	3	ISO 4762 - M5 x 30	
53	Innensechskantschraube	Socket head screw	2	ISO 4762 - M5 x 10	
54	Spannstift	Spring pin	1	ISO 8752 - 5 x 20 A	
55	Innensechskantschraube	Socket head screw	2	ISO 4762 - M4 x 8	
56	Innensechskantschraube	Socket head screw	4	ISO 4762 - M6 x 12	
57	Innensechskantschraube	Socket head screw	2	ISO 4762 - M4 x 10	
58	Hülse	Sleeve	1		03427205458
59	Gewindestift	Grub screw	4	ISO 4026 - M3 x 10	
60	Sechskantmutter	Hexagon nut	4	ISO 4032 - M3	
61	Platte	Plate	1		03427205461
62	Platte	Plate	1		03427205462
63	Innensechskantschraube	Socket head screw	3	ISO 4762 - M5 x 12	
64	Sicherungsring	Retaining ring	2	DIN 471 - 8x0,8	
65	Gewindestift	Grub screw	1	DIN 913 - M5 x 8	
66	Spannstift	Spring pin	1	ISO 13337 - 5 x 20	
67	Schraube	Screw	1		03427205467
68	Schlossmutter	Lock nut	1		03427205468
69	Zahnrad	Gear	1		03427205469

TU3008G\_parts.fm

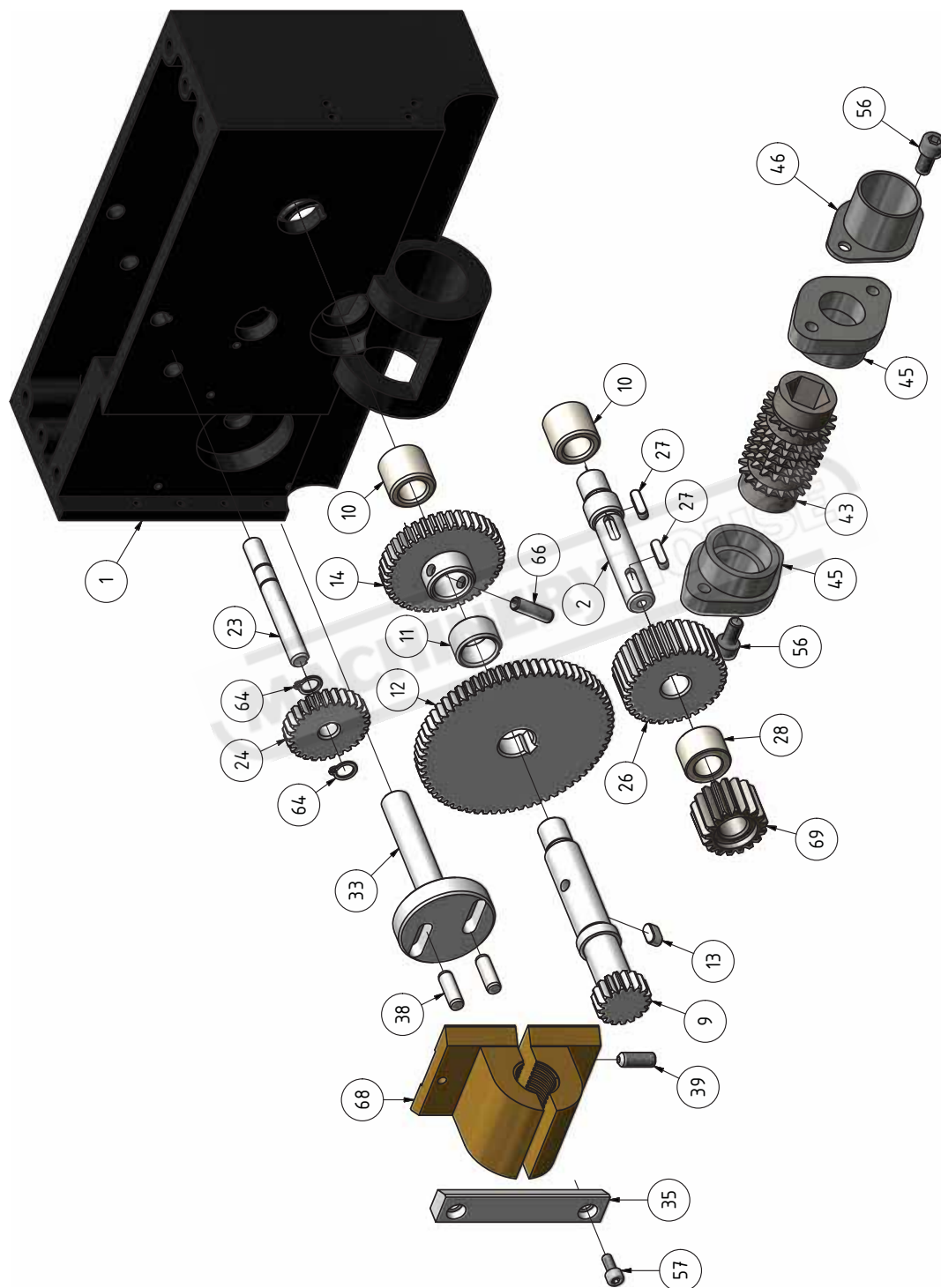
## L Planschlitten - Cross slide



Abb.6-11: Planschlitten - Cross slide



TU3008G - Teileliste Planschlitten - Cross slide parts list					
Pos.	Bezeichnung	Description	Menge	Grösse	Artikelnummer
			Qty.	Size	Item no.
1	Führung	Guide	1		03427205601
17	Spindel	Spindle	1		03427205617
18	Planschlitten	Cross slide	1		03427205618
20	Spindelmutter	Spindle nut	1		03427205620
21	Lagerbock	Bearing block	1		03427205621
22	Flansch	Flange	1		03427205622
23	Axiallager	Thrust bearing	2	51101	04051101
24	Zahnrad	Gear	1		03427205624
25	Passfeder	Fitting key	2	4x10	
26	Skalenring	Scale ring	1		03427205626
27	Handrad	Handle	1		03427205627
28	Schraube	Screw	1	M5x8	
35	Hülse	Sleeve	1		03427205635
36	Schraube	Screw			03427205636
37	Platte	Plate	1		03427205637
38	Platte	Plate	1		03427205638
39	Platte	Plate	1		03427205639
40	Platte	Pa	1		03427205640
41	Abstreifer	Wipper	1		03427205641
42	Platte	Plate	1		03427205642
43	Abstreifer	Wiper	1		03427205643
48	Innensechskantschraube	Socket head screw	12	ISO 4762 - M4 x 12	
51	Innensechskantschraube	Socket head screw	4	ISO 4762 - M10 x 30	
52	Innensechskantschraube	Socket head screw	4	ISO 4762 - M8 x 35	
53	Innensechskantschraube	Socket head screw	11	ISO 4762 - M6 x 16	
54	Innensechskantschraube	Socket head screw	2	ISO 4762 - M8 x 16	
55	Keilleiste	Gib	1		03427205655
56	Einstellschraube	Adjust screw	2		03427205656
60	Schmiernippel	Lubrication cup	8		03427205660
64	Zylinderstift	Cylindrical pin	2	ISO 2338 - 6 h8 x 30 - B	
66	Innensechskantschraube	Socket head screw	5	ISO 4762 - M4 x 10	

## M Oberschlitten - Top slide

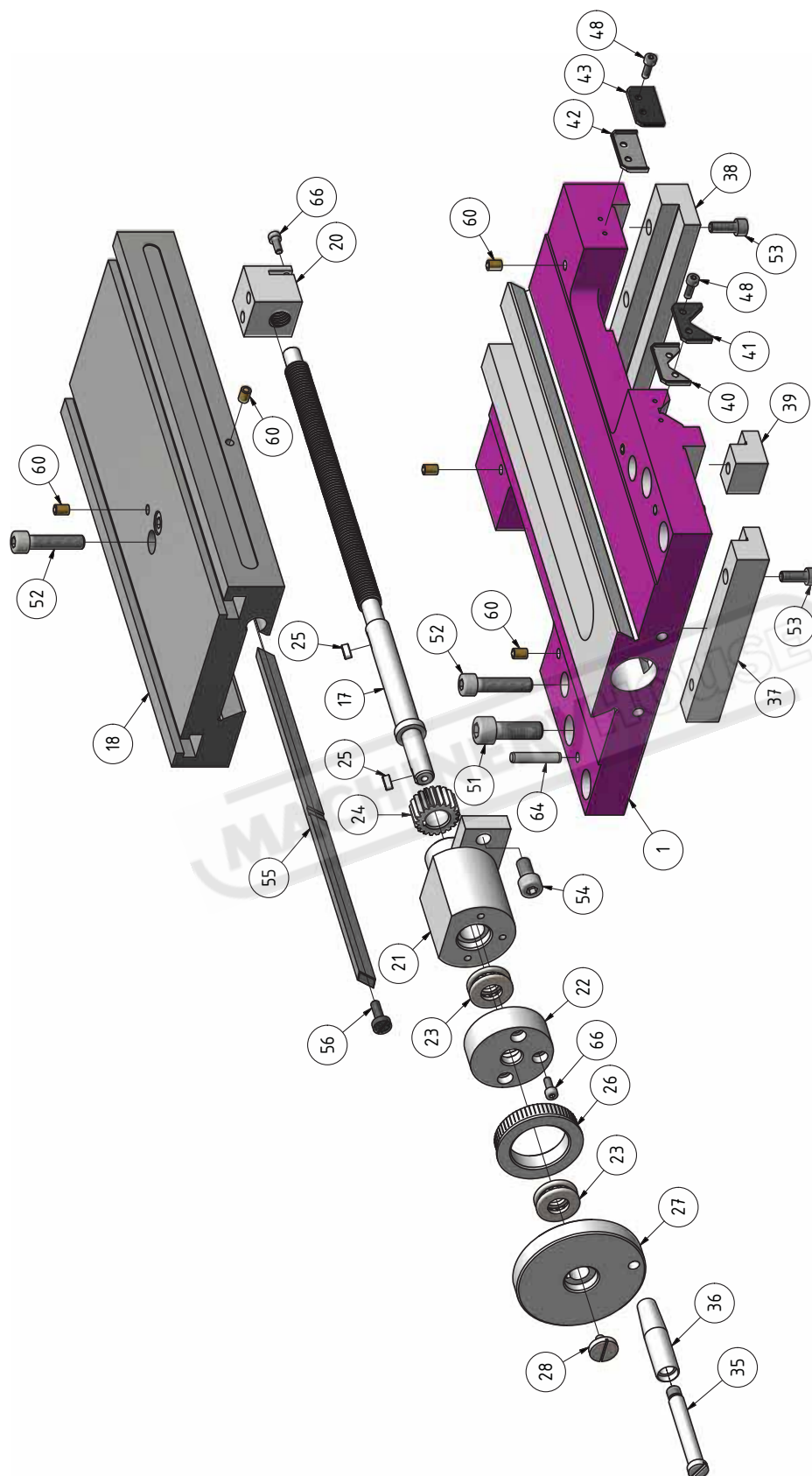

Abb.6-12: Oberschlitten - Top slide

TU3008G - Teileliste Oberschlitten - Top slide parts list					
Pos.	Bezeichnung	Description	Menge	Grösse	Artikelnummer
			Qty.	Size	Item no.
2	Welle	Shaft	1		03427205702
3	Aufnahme	Collet	1		03427205703
4	Hebel	Lever	1		03427205704
5	Scheibe	Washer	1		03427205705
6	Vierkantstahlhalter	Toolholder	1		03427205706
7	Oberschlitten	Top slide	1		03427205707
13	Keilleiste	Gib	1		03427205713
14	Skalenring	Scala ring	1		03427205714
15	Führung	Guide	1		03427205715
16	Spindelmutter	Spindle nut	1		03427205716
17	Führung	Guide	1		03427205715
19	Klemmplatte	Clamping-plate	1		03427205719
50	Innensechskantschraube	Socket head screw	2	ISO 4762 - M5 x 12	
53	Innensechskantschraube	Socket head screw	11	ISO 4762 - M6 x 16	
57	Schraube	Screw	8	M8-35	
58	Nutenschraube	Screw	2		03427205758

TU3008G\_parts.fm

59	Sechskantmutter	Hexagon nut	2	ISO 4032 - M10	
60	Schmiernippel	Lubrication cup	8		03427205760
61	Gewindestift	Grub screw	1	ISO 4026 - M6 x 20	
62	Sechskantmutter	Hexagon nut	1	ISO 4032 - M6	
65	Zylinderstift	Cylindrical pin	1	ISO 2338 - 4 h8 x 20	
67	Feder	Spring	1		03427205767
68	Rastbolzen	Bolt	1		03427205768
71	Spannstift	Spring pin	1	ISO 13337 - 3 x 10	
72	Spindel	Spindle	1		03427210772
73	Passfeder	Fitting key	1	3x10	
74	Schmiernippel	Lubrication cup	1		03427210774
75	Lagerbock	Bearing block	1		03427210775
76	Skalenring	Scala ring	1		03427210776
77	Federblech	Spring plate	1		03427210777
78	Handrad	Handle	1		03427210778
79	Handhebel	Handle lever	2		03427210779
80	Späneschutz	Chip protection	1		034272004001
81	Halter	Holder	1		034272004002
82	Welle	Shaft	1		034272004003
83	Hülse	Sleeve	1		034272004004

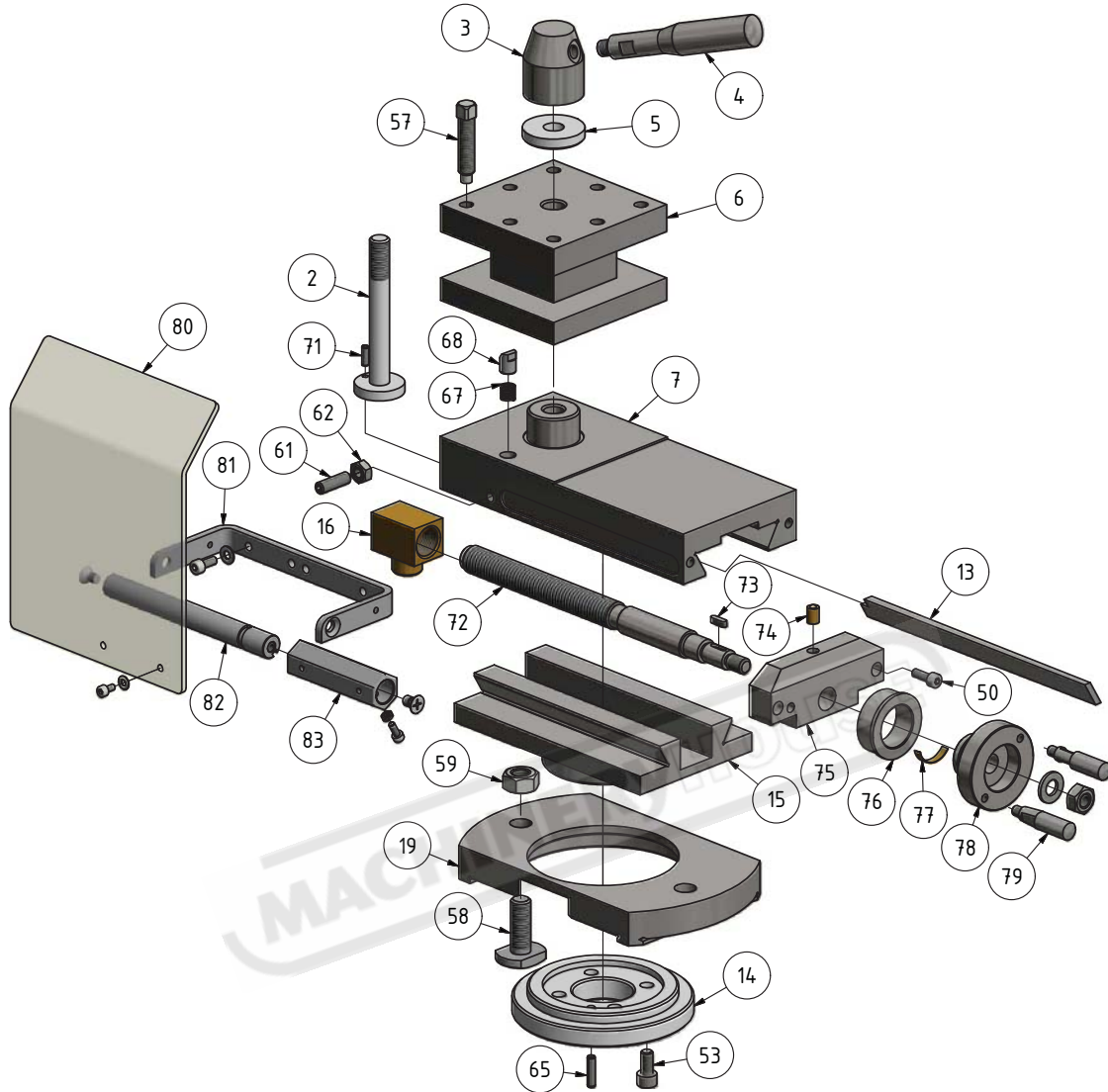
MACHINERYHOUSE

## N Maschinenbett - Machine bed



Abb.6-13: Maschinenbett - Machine bed

TU3008G\_parts.fm

TU3008G - Teilleiste Maschinenbett - Machine bed parts list					
Pos.	Bezeichnung	Description	Menge	Grösse	Artikelnummer
			Qty.	Size	Item no.
1	Maschinenbett	Machine bed	1		03427205801
2	Abdeckung	Cover	1		03427205802
3	Leitspindel	Lead screw	1	pitch 2.5mm	03427205803
4	Axiallager	Thrust bearing	3	51102	01051102
5	Nutmutter	Groove nut	2		03427205805
13	Schild	Label	1		03427205813
14	Zahnstange	Rack	2		03427205814
15	Zugspindel	Feed rod	1		03427205815
16	Lagerbock	Bearing block	1		03427205816
25	Halter	Holder	1		03427205825
26	Schraube	Screw	2		03427205826
27	Halter	Holder	1		03427205827
28	Halter	Holder	1		03427205828
29	Halter	Holder	1		03427205829
31	Abdeckung	Cover	1		03427205831
32	Schraube	Screw	4		03427205832
33	Spiralabdeckung	Spirale cover	1		03427205833
34	Spiralabdeckung	Spirale cover	1		03427205834
35	Spiralabdeckung	Spirale cover	1		03427205835
36	Spiralabdeckung	Spirale cover	1		03427205836
38	Innensechskantschraube	Socket head screw	6		03427205838
39	Zylinderstift	Cylindrical pin	4		03427205839
40	Schraube	Screw	4		03427205840
41	Schmiernippel	Lubrication cup	2		03427205841
43	Bolzen	Bolt	1		03427205843
45	Spänwanne	Chip tray	1		03427210845
46	Spritzwand	Splashback	1		03427210846

## O Reitstock - Tailstock

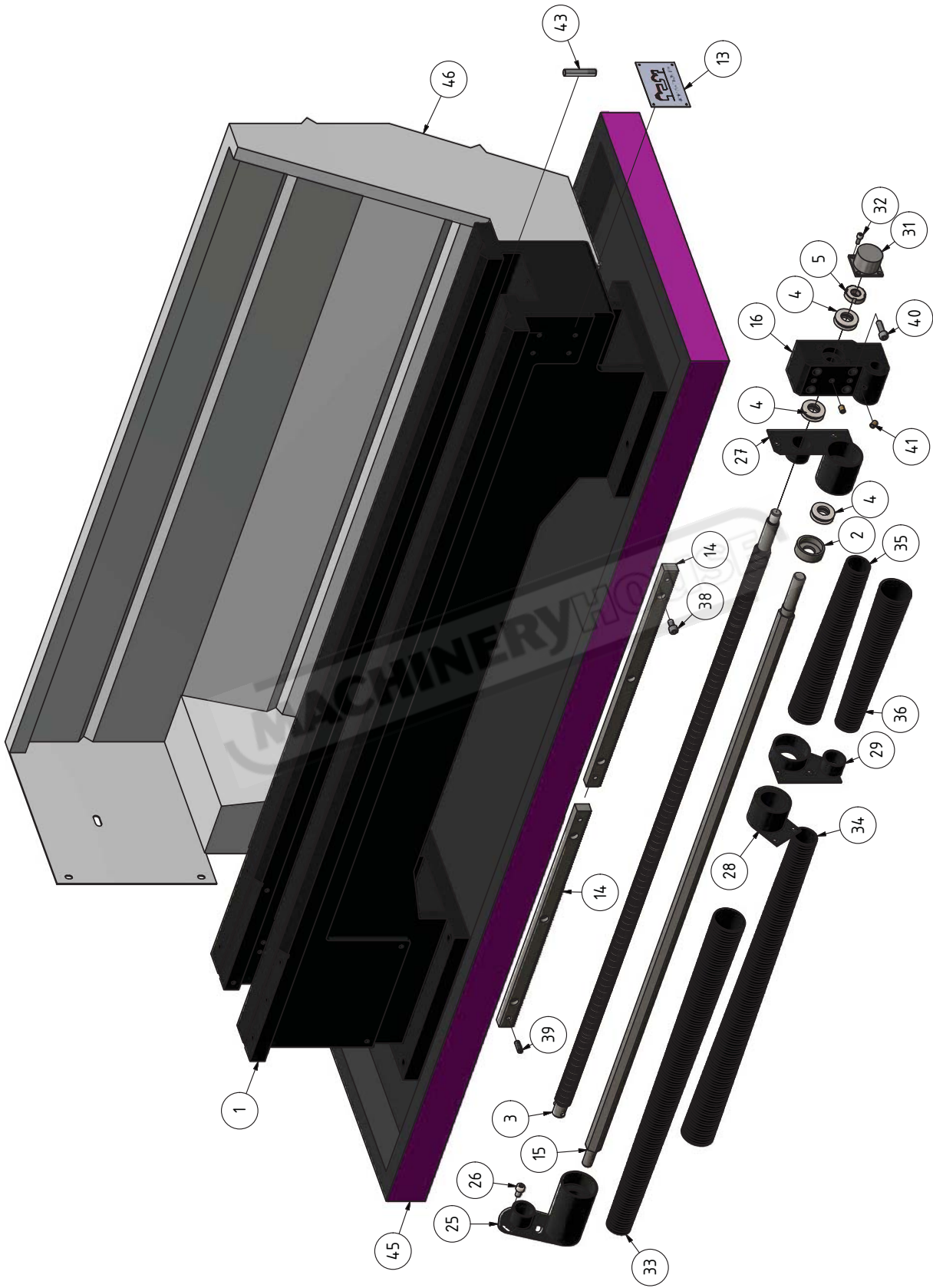

Abb.6-14: Reitstock - Tailstock

TU3008G - Teilleiste Reitstock - Tailstock parts list					
Pos.	Bezeichnung	Description	Menge	Grösse	Artikelnummer
			Qty.	Size	Item no.
1	Platte	Plaze	1		03427205901
2	Gehäuse	Housing	1		03427205902
3	Exzenter	Eccentric	1		03427205903
4	Platte	Plate	1		03427205904
5	Bolzen	Bolt	1		03427205905
6	Buchse	Bushing	1		03427205906
7	Spindel	Spindle	1		03427205907
8	Lagerbock	Bearing block	1		03427205908
9	Pinole	Sleeve	1		03427205909
10	Klemmplatte	Clamping plate	1		03427205910
11	Axiallager	Thrust bearing	1	51200	04051200

TU3008G\_parts.fm

12	Hebel	Lever	1		03427205912
13	Sechskantschraube	Hexagon screw	1	M8x80	
14	Handrad	Handle	1		03427205914
15	Skalenring	Scale ring	1		03427205915
16	Scheibe	Washer	1	8	
17	Sechskantmutter	Hexagon nut	1	M8x80	
18	Handgriff	Handle	1		03427205918
19	Schmiernippel	Lubrication cup	2		03427205919
20	Innensechskantschraube	Socket head screw	4	ISO 4762 - M5 x 20	
21	Gewindestift	Grub screw	1	DIN 915 - M5 x 12	
22	Zentrierstück	Center piece	1		03427205922
23	Passfeder	Fitting key	1	DIN 6885 - A 4 x 4 x 12	
24	Federblech	Spring	1		03427205924
25	Gewindestift	Grub screw	3	DIN 915 - M8 x 30	
26	Spannstift	Spring pin	1	ISO 13337 - 4 x 28	
27	Sechskantschraube	Hexagon screw	1	ISO 4014 - M4 x 30	
28	Unterlegscheibe	Washer	1	DIN 125 - A 4,3	
29	Hebel	Lever	1		03427205929
30	Skala	Scala	1		03427205930
31	Skala	Scala	1		03427205931

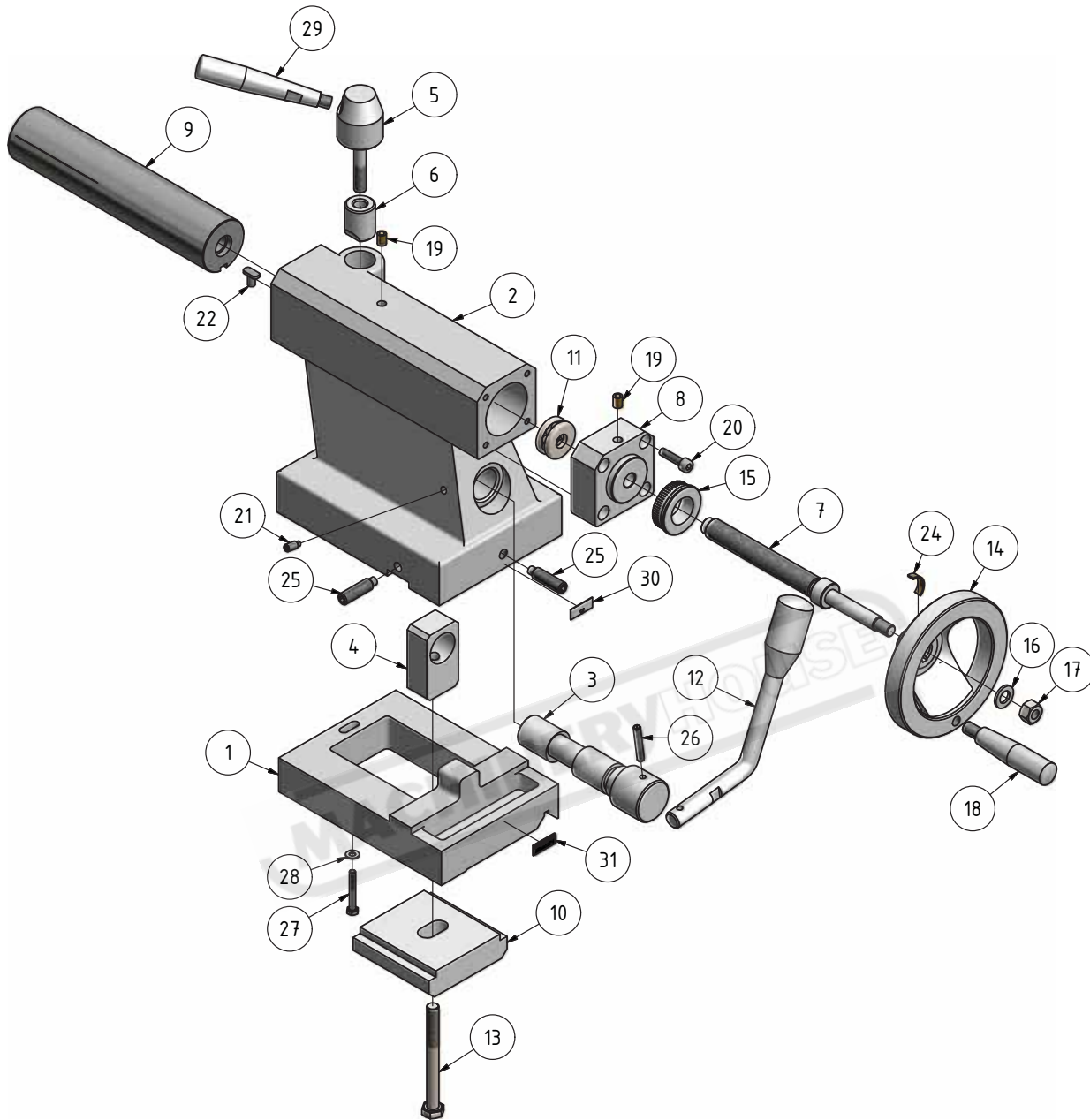
## P Mitlaufende Lünette - Follow steady rest



Abb.6-15: Mitlaufende Lünette - Follow steady rest

TU3008G - Teilleiste mitlaufende Lünette - Follow steady rest parts list					
Pos.	Bezeichnung	Description	Menge	Grösse	Artikelnummer
			Qty.	Size	Item no.
1	Mitlaufende Lünette	Follow rest	1		3441460
2	Messingstift	Brass pin	2		
3	Schraube	Screw	2		
4	Scheibe	Washer	2	8	
5	Sechskantmutter	Hexagon nut	2	M8	
6	Einstellschraube	Ajust screw	2		
7	Scheibe	Washer	2	DIN 125 - A 8,4	
8	Innensechskantschraube	Socket head screw	2	ISO 4762 - M8 x 30	

TU3008G\_parts.fm

## Q Feststehende Lünette - Fixed steady rest

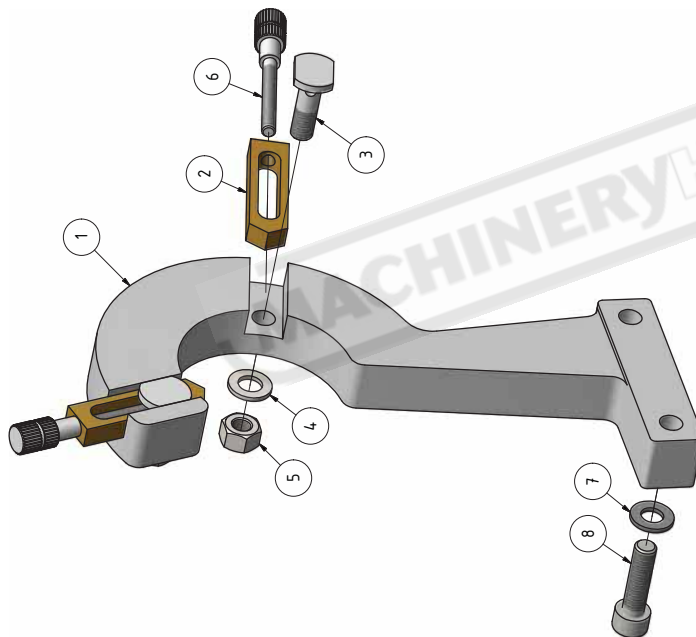

Abb.6-16: Feststehende Lünette - Fixed steady rest

TU3008G - Teileliste feststehende Lünette - Fixed steady rest parts list					
Pos.	Bezeichnung	Description	Menge	Grösse	Artikelnummer
			Qty.	Size	Item no.
1	Feststehende Lünette	Steady rest	1		3441461
2	Messingstift	Brass pin	3		
3	Schraube	Screw	3		
4	Scheibe	Washer	3	8	
5	Sechskantmutter	Hexagon nut	3	M8	
6	Einstellschraube	Ajust screw	3		
7	Sechskantmutter	Hexagon nut	1	M12	
8	Scheibe	Washer	1		
9	Klemmplatte	Clamping plate	1		
10	Sechskantschraube	Hexagon screw	1	M12x70	



## R Drehfutterschutz - Lathe chuck cover

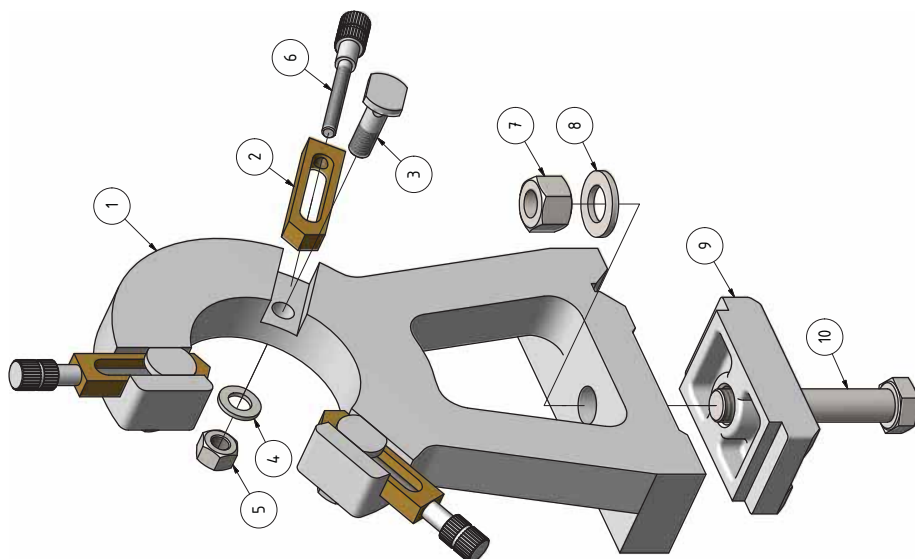

Abb.6-17: Drehfutterschutz - Lathe chuck cover

TU3008G - Teilleiste Drehfutterschutz - Lathe chuck guard parts list					
Pos.	Bezeichnung	Description	Menge	Grösse	Artikelnummer
			Qty.	Size	Item no.
1	Ring	Ring	1		034272003001
2	Platte	Plate	1		034272003002
3	Ring rechts	Ring right	1		034272003003
4	Drehfutterschutz	Lathe chuck cover	1		034272003004
5	Rolle	Roll	3		034272003005
6	Gummistopper	Rubber end stopper	2		034272003006
7	Buchse	Bushing	3		034272003007
8	Platte	Plate	1		034272003008
9	Schalter Drehfutterschutz	Lathe chuck protection switch	1	Single channel TZ 3112	034272001S4
	Schalter Drehfutterschutz	Lathe chuck protection switch	1	Double channel TZ 3112	034272001S42K
10	Ring links	Ring left	1		034272003010
11	Sechskantmutter	Hexagen nut	2	ISO 4032 - M6	
12	Scheibe	Washer	5	DIN 125 - A 6,4	
13	Senkschraube	Screw	2	DIN 7991 - M5x8	
14	Innensechskantschraube	Socket head screw	2	ISO 4762 - M3 x 20	
15	Innensechskantschraube	Socket head screw	3	ISO 4762 - M3 x 12	
16	Innensechskantschraube	Socket head screw	3	ISO 4762 - M3 x 8	
17	Abstandsbuchse	Bushing	3		034272003017
18	Innensechskantschraube	Socket head screw	3	ISO 4762 - M6 x 20	
19	Handgriff	Handle	1		034272003019

## S Maschinenschilder - Machine labels

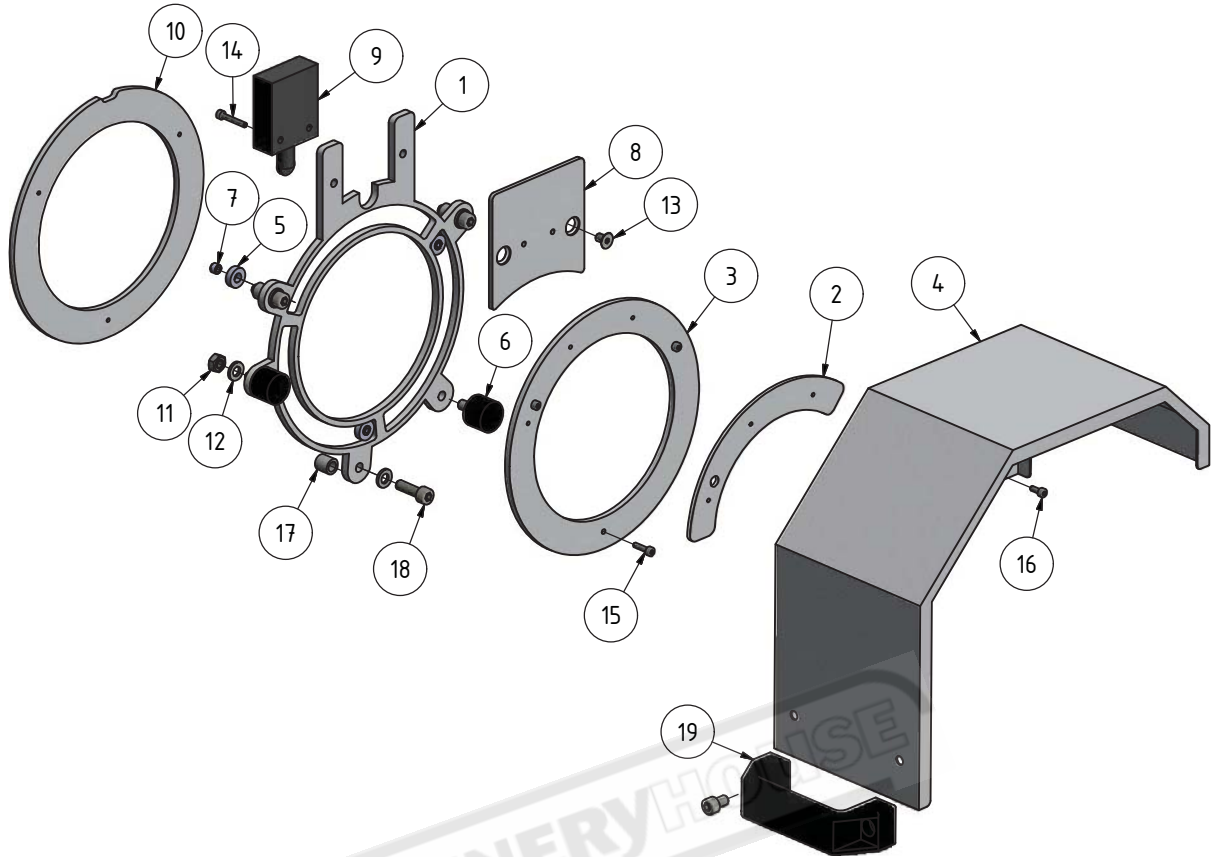

Abb.6-18: Maschinenschilder - Machine labels

TU3008G - Ersatzteilliste Maschinenschilder - Machine labels spare part list					
Pos.	Bezeichnung	Description	Menge	Grösse	Artikelnummer
			Qty.	Size	Item no.
1	Schild Frontabdeckung	Front lable	1		03427210L01
2	Maschinenschild	Machine lable	1		03427210L02
3	Drehzahl Schild	Rotation speed lable	1		03427210L03
4	Schild Hauptschalter	Main switch lable	1		03427200L04
5	Schild Schlossmutter	Claps nut lable	1		03427200L05
6	Schild Drehrichtung	Rotating derrection lable	1		03427200L06
7	Schild Vorschub	Feed lable	1		03427200L07
8	Schild Anzeige	Indicator lable	1		03427200L08
9	Schild Sicherheit	Safety lable	1		03427200L09

## 6.5 Schaltplan - Wiring diagram

### T Einkanalig - Single channel

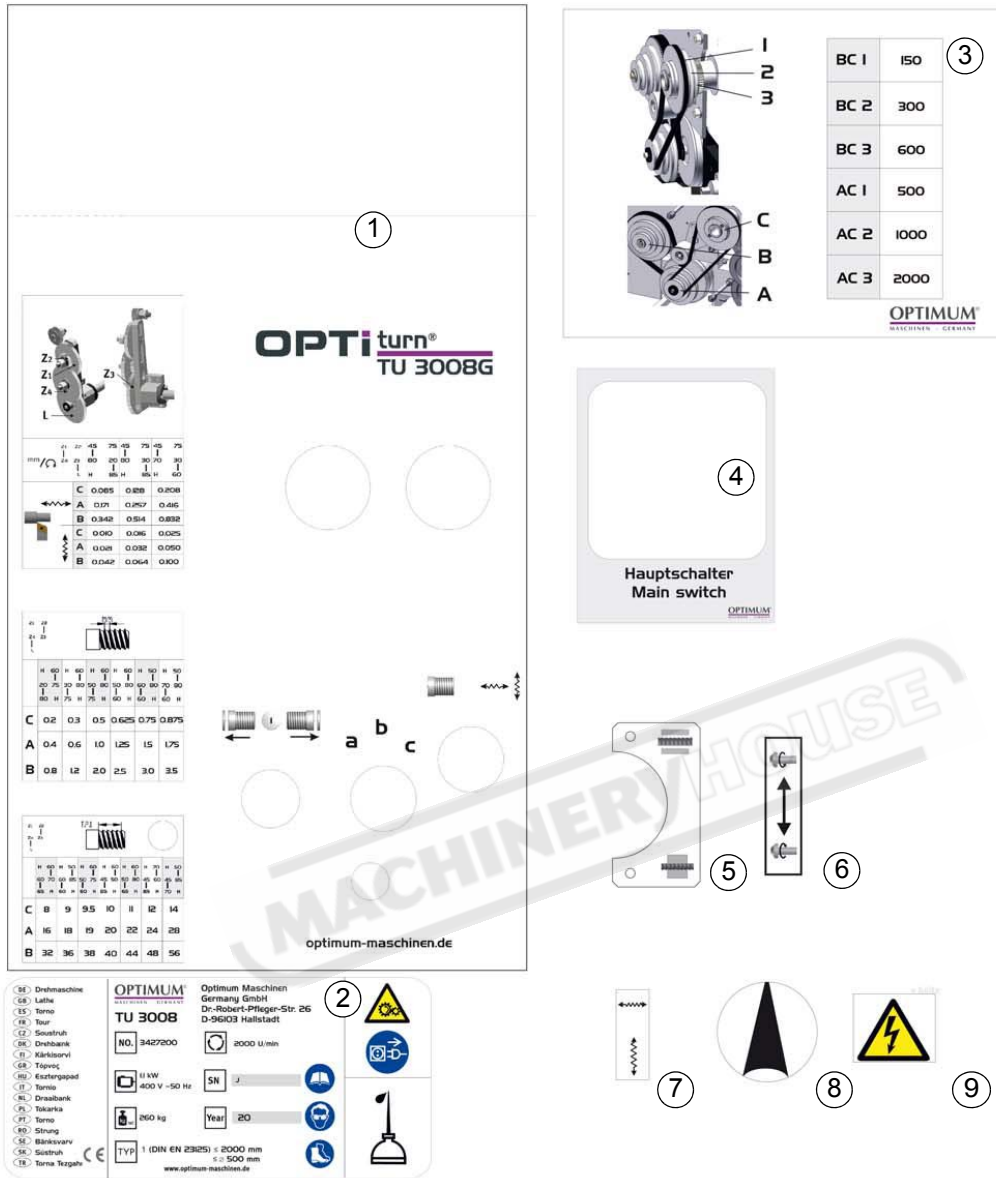
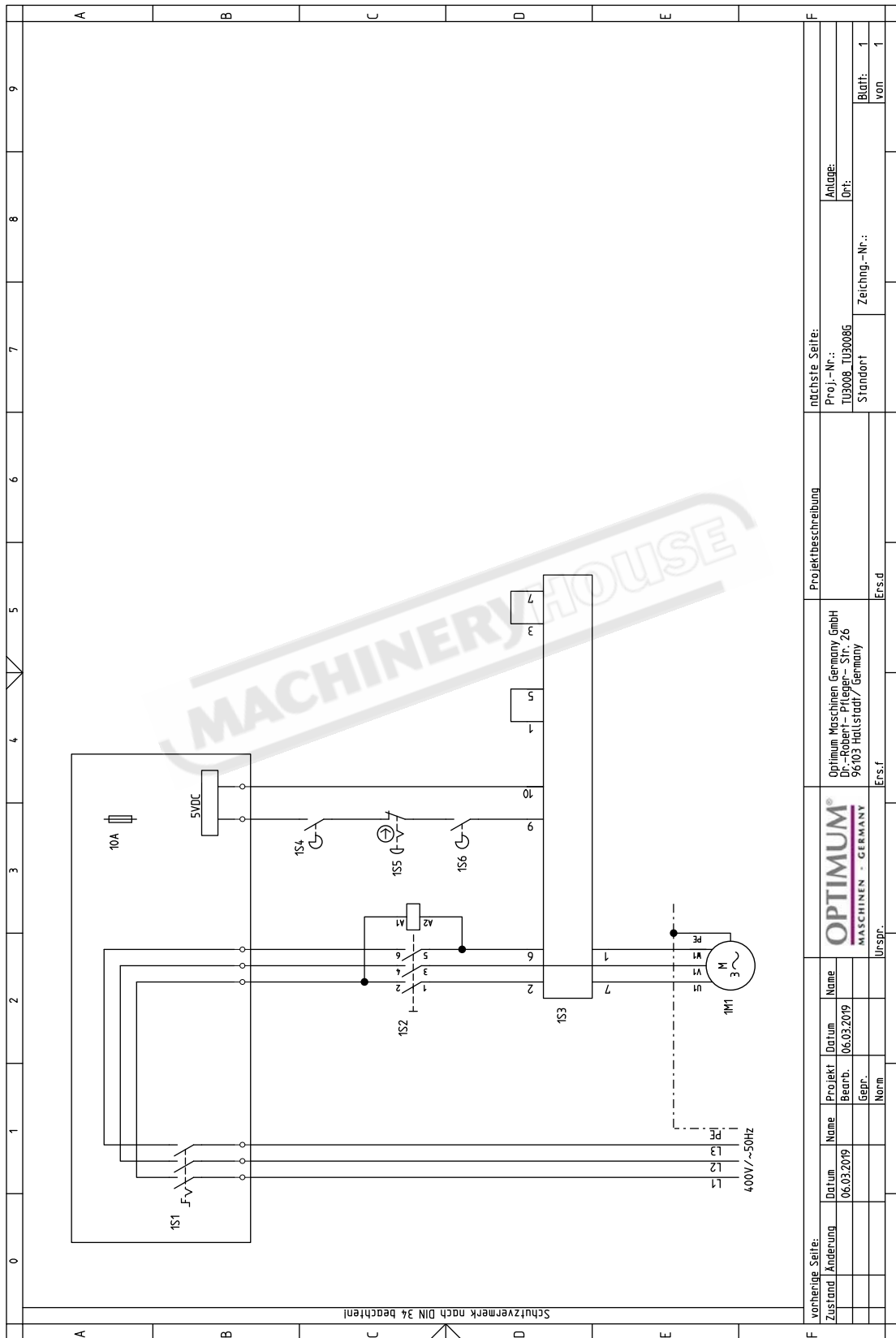

TU3008G\_parts.fm

Abb.6-19:

TU3008G - Teilleiste einkanalige elektrische Bauteile - Single channel electrical parts list					
Pos.	Bezeichnung	Description	Menge	Grösse	Artikelnummer
			Qty.	Size	Item no.
1S1	Motorschutzschalter mit Hauptschalter	Motor protection switch with main switch	1	MP03	034272001S1
1S2	Ein-Aus Schalter	On-Off switch	1	KJD18	034272001S2
1S3	Drehrichtungsschalter	Change-over switch	1	ZH-A	034272001S3
1S4	Schalter Drehfutterschutz	Lathe chuck protection switch	1	TZ 3112, single channel	034272001S4
1S5	Not-Halt Schalter	Emergency stop switch	1	HY57B	034272001S3
1S6	Verriegelungsschalter Schutzabdeckung	Interlock switch, protective cover change gears	1	QKS8	034272001S5
1M1	Antriebsmotor	Drive motor	1	400V	034272001M3
	Sicherung	Fuse	1	10A	044408208



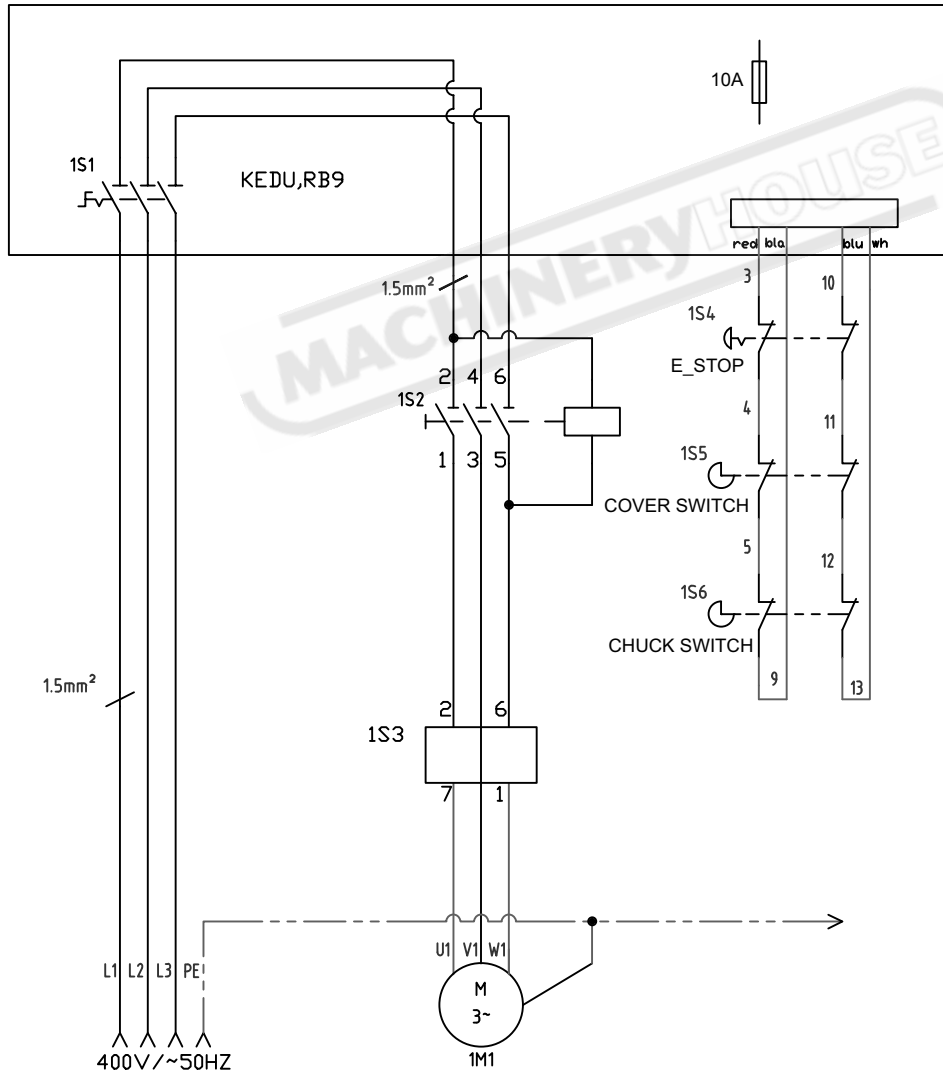



## U Zweikanalig - Double channel



TU3008G\_parts.fm

TU3008G - Teileliste zweikanalige elektrische Bauteile - Double channel electrical parts list					
Pos.	Bezeichnung	Description	Menge	Grösse	Artikelnummer
			Qty.	Size	Item no.
1S1	Motorschutzschalter mit Hauptschalter	Motor protection switch with main switch	1	Kedu, RB9	034272001S12K
1S2	Ein-Aus Schalter	On-Off switch	1	KJD18	034272001S2
1S3	Drehrichtungsschalter	Change-over switch	1	ZH-A	034272001S3
1S6	Schalter Drehfutterschutz	Lathe chuck protection switch	1	TZ 3112, zweikanalig	034272001S42K
1S4	Not-Halt Schalter	Emergency stop switch	1	HY57B	034272001S3
1S5	Verriegelungsschalter Schutzabdeckung	Interlock switch, protective cover change gears	1	QKS8	034272001S5
1M1	Antriebsmotor	Drive motor	1	400V	034272001M3
	Sicherung	Fuse	1	10A	044408208

MACHINERYHOUSE

Schmierstoffe Lubricant Lubrifiant	Viskosität Viskosity Viscosité ISO VG DIN 51519 mm <sup>2</sup> /s (cSt)	Kennzeichnung nach DIN 51502							
Getriebeöl Gear oil Huile de réducteur	VG 680	CLP 680	Aral Degol BG 680	BP Energol GR-XP 680	SPARTAN EP 680	Klüberoil GEM 1-680	Mobilgear 636	Shell Omala 680	Meropa 680
	VG 460	CLP 460	Aral Degol BG 460	BP Energol GR-XP 460	SPARTAN EP 460	Klüberoil GEM 1-460	Mobilgear 634	Shell Omala 460	Meropa 460
	VG 320	CLP 320	Aral Degol BG 320	BP Energol GR-XP 320	SPARTAN EP 320	Klüberoil GEM 1-320	Mobilgear 632	Shell Omala 320	Meropa 320
	VG 220	CLP 220	Aral Degol BG 220	BP Energol GR-XP 220	SPARTAN EP 220	Klüberoil GEM 1-220	Mobilgear 630	Shell Omala 220	Meropa 220
	VG 150	CLP 150	Aral Degol BG 150	BP Energol GR-XP 150	SPARTAN EP 150	Klüberoil GEM 1-150	Mobilgear 629	Shell Omala 150	Meropa 150
	VG 100	CLP 100	Aral Degol BG 100	BP Energol GR-XP 100	SPARTAN EP 100	Klüberoil GEM 1-100	Mobilgear 627	Shell Omala 100	Meropa 100
	VG 68	CLP 68	Aral Degol BG 68	BP Energol GR-XP 68	SPARTAN EP 68	Klüberoil GEM 1-68	Mobilgear 626	Shell Omala 68	Meropa 68
	VG 46	CLP 46	Aral Degol BG 46	BP Bartran 46	NUTO H 46 (HLP 46)	Klüberoil GEM 1-46	Mobil DTE 25	Shell Tellus S 46	Anubia EP 46
	VG 32	CLP 32	Aral Degol BG 32	BP Bartran 32	NUTO H 32 (HLP 32)	Klübersynth GEM 4- 32 N	Mobil DTE 24	Shell Tellus S 32	Anubia EP 32
Hydrauliköl Hydraulic oil Huile hydraulique	VG 32	CLP 32	Aral Vitam GF 32	BP Energol HLP HM 32	NUTO H 32 (HLP 32)	LAMORA HLP 32	Mobil Nuto HLP 32	Shell Tellus S2 M 32	Rando HD HLP 32
	VG 46	CLP 46	Aral Vitam GF 46	BP Energol HLP HM 46	NUTO H 46 (HLP 46)	LAMORA HLP 46	Mobil Nuto HLP 46	Shell Tellus S2 M 46	Rando HD HLP 46
Getriebefett Gear grease Graisse de réducteur		G 00 H-20	Aral FDP 00 (Na-verseift) Aralub MFL 00 (Li-verseift)	BP Energol PR-EP 00	FIBRAX EP 370 (Na-verseift)	MICRO-LUBE GB 00	Mobilux EP 004	Shell Alvania GL 00 (Li-verseift)	Marfak 00

oil-compare-list.fm

Spezialfette, wasserabweisend Special greases, water resistant Graisses spéciales, déperlant			Aral Aralub	Energrease PR 9143		ALTEMP Q NB 50 Klüberpaste ME 31-52	Mobilux EP 0 Mobil Greaserex 47		
Wälzlagerfett Bearing grease Graisse de roulement		K 3 K-20 (Li-verseift)	Aralub HL 3	BP Energrease LS 3	BEACON 3	CENTOPLEX 3	Mobilux 3	Shell Alvania R 3 Alvania G 3	Multifak Premium 3
Öle für Gleitbahnen Oils for slideways Huiles pour glissières	VG 68	CGLP 68	Aral Deganit BWX 68	BP Maccurat D68	ESSO Febis K68	LAMORA D 68	Mobil Vactra Oil No.2	Shell Tonna S2 M 68	Way lubricant X 68
Öle für Hochfrequenzspindeln Oils for Built-in spindles Huiles pour broches à haute vitesse	VG 68		Deol BG 68	Emergol HLP-D68	Spartan EP 68		Drucköl KLP 68-C	Shell Omala 68	
Fett für Zentralschmierung (Fließfett) Grease for central lubrication Graisse pour lubrification centrale	NLGI Klasse 000 NLGI class 000		ARALUB BAB 000	Grease EP 000	Shell Gadus S4 V45AC	CENTOPLEX GLP 500	Mobilux EP 023		Multifak 264 EP 000
Fett für Hochfrequenzspindeln Grease for Built-in spindles Graisse pour broches à haute vitesse	<p>METAFLUX-Fett-Paste (Grease paste) Nr. 70-8508          METAFLUX-Moly-Spray Nr. 70-82          Techno Service GmbH ; Detmolder Strasse 515 ; D-33605 Bielefeld ; (+49) 0521- 924440 ; <a href="http://www.metaflux-ts.de">www.metaflux-ts.de</a></p>								
Kühlschmiermittel Cooling lubricants Lubrifiants de refroidissement	Schneidöl Aquacut C1, 10 L Gebinde, Artikel Nr. 3530030 EG Sicherheitsdatenblatt <a href="http://www.optimum-daten.de/data-sheets/Optimum-Aquacut_C1-EC-datasheet_3530030_DE.pdf">http://www.optimum-daten.de/data-sheets/Optimum-Aquacut_C1-EC-datasheet_3530030_DE.pdf</a>		Aral Emusol	BP Sevora	Esso Kutwell		Mobilcut	Shell Adrana	Chevron Soluble Oil B



## 7 Malfunctions

Malfunction	Cause/ possible effects	Solution
Machine does not turn on	<ul style="list-style-type: none"> <li>Position switch lathe chuck protection machine switches off</li> <li>Position switch protection cover headstock machine switches off</li> <li>Emergency-stop mushroom switch activated</li> <li>Motor protection switch has triggered by overloading.</li> </ul>	<ul style="list-style-type: none"> <li>Check position switch lathe chuck protection, adjust</li> <li>Check or adjust the position switch of protective cover headstock.</li> <li>Emergency-stop mushroom switch unlock</li> <li>Avoid overloading. Activate the motor circuit breaker again. 🔧 Resetting the motor circuit breaker on page 29</li> </ul>
Motor is hot Motor has no power	<ul style="list-style-type: none"> <li>Machine connected incorrectly</li> </ul>	<ul style="list-style-type: none"> <li>🔧 Electrical connection on page 24</li> </ul>
Feed will stop	<ul style="list-style-type: none"> <li>Clutch of the longitudinal feed or cross feed will slip.</li> </ul>	<ul style="list-style-type: none"> <li>Cutting force too high</li> <li>If necessary, check clutch and readjust. 🔧 Clutch feed rod on page 72</li> </ul>
Surface of workpiece too rough	<ul style="list-style-type: none"> <li>Lathe tool blunt</li> <li>Lathe tool springs</li> <li>Feed too high</li> <li>Radius at lathe tool tip too small</li> </ul>	<ul style="list-style-type: none"> <li>Resharpen lathe tool</li> <li>Clamp lathe tool with less overhang</li> <li>Reduce feed</li> <li>Increase radius</li> </ul>
V-belt squeaks V-belt slips	<ul style="list-style-type: none"> <li>V-belt wear down</li> <li>V-belt tension is too loose</li> </ul>	<ul style="list-style-type: none"> <li>🔧 V-belt check, re-tighten on page 71</li> </ul>
Speed of rotation varies too much		
Workpiece becomes conical	<ul style="list-style-type: none"> <li>Centre are not aligned (tailstock off-set)</li> <li>Top slide is not exactly set to zero (when turning with the top slide)</li> </ul>	<ul style="list-style-type: none"> <li>Align the tailstock to the center</li> <li>Align the top slide exactly</li> </ul>
Lathe rattles	<ul style="list-style-type: none"> <li>Feed too high</li> <li>Spindle bearings have too much clearance.</li> </ul>	<ul style="list-style-type: none"> <li>Reduce feed</li> <li>Readjust spindle bearings. 🔧 Spindle bearing on page 73</li> </ul>
Centering point runs hot	<ul style="list-style-type: none"> <li>Workpiece has expanded</li> </ul>	<ul style="list-style-type: none"> <li>Loosen tailstock center</li> </ul>
Lathe tool has a short service life	<ul style="list-style-type: none"> <li>Cutting speed too high</li> <li>For large infeed</li> <li>Insufficient cooling</li> </ul>	<ul style="list-style-type: none"> <li>Reduce cutting speed</li> <li>Lower delivery / finishing stock allowance not over 0.5 mm)</li> <li>More cooling</li> </ul>
Flank wear too high	<ul style="list-style-type: none"> <li>Clearance angle too small (lathe tool "pushes")</li> <li>Lathe tool tip not adjusted to centre height</li> </ul>	<ul style="list-style-type: none"> <li>Increase clearance angle</li> <li>Correct height adjustment of the lathe tool</li> </ul>
Cutting edge breaks off	<ul style="list-style-type: none"> <li>Wedge angle too small (heat buildup)</li> <li>Grinding cracks due to improper cooling</li> <li>Excessive play in the spindle bearings (oscillations occur)</li> </ul>	<ul style="list-style-type: none"> <li>Set greater wedge angle</li> <li>Cool uniformly</li> <li>Have the clearance in the spindle bearing arrangement re-adjusted 🔧 Spindle bearing on page 73</li> </ul>

TU3008G\_GB\_7.fm





Malfunction	Cause/ possible effects	Solution
Turned thread is wrong	<ul style="list-style-type: none"> <li>• Lathe tool is clamped incorrectly or grinding has been started the wrong way</li>   <li>• Wrong pitch</li> <li>• Wrong diameter</li> </ul>	<ul style="list-style-type: none"> <li>• Set the lathe tool to the centre, grind angle correctly Use 60° lathe tool for metric threads, 55° lathe tool for inch thread</li> <li>• Adjust right pitch</li> <li>• Turn the workpiece to the correct diameter</li> </ul>

MACHINERYHOUSE



## 8 Appendix

### 8.1 Copyright

This document is protected by copyright. All derived rights are reserved, especially those of translation, re-printing, use of figures, broadcast, reproduction by photo-mechanical or similar means and recording in data processing systems, either partial or total.

Subject to technical changes without notice.

### 8.2 Terminology/Glossary

Term	Explanation
Headstock	Housing for the feed gear and the synchronous belt pulleys.
Lead screw nut	Split nut which engages the lead screw.
Lead screw	Threaded shaft for tapping threads
Feed rod	Shaft without threads for transferring the feed to the saddle or cross slide.
Lathe chuck	Clamping tool for holding the workpiece.
Drill chuck	Drill bit adapter
Lathe saddle	Slide on the slideway of the machine bed which feeds parallel to the tool axis.
Cross slide	Slide on the slideway of the machine bed which feeds parallel to the tool axis.
Top slide	Swivelling slide on the cross slide.
Taper mandrel	Taper of the drill bit, the drill chuck or the centering point.
Tool	Lathe tool, drill bit, etc.
Workpiece	Piece to be turned or machined.
Tailstock	Movable turning aid.
rest	Follow or steady support for turning long workpieces.
Lathe dog	Device or clamping aid for driving pieces to be turned between centres.
Threading gauge	Help with thread cutting



## 8.3 Liability claims/warranty

Besides the legal liability claims for defects of the customer towards the seller, the manufacturer of the product, OPTIMUM GmbH, Robert-Pfleger-Straße 26, D-96103 Hallstadt, does not grant any further warranties unless they are listed below or were promised as part of a single contractual provision.

- Liability or warranty claims are processed at OPTIMUM GmbH's discretion either directly or through one of its dealers.  
Any defective products or components of such products will either be repaired or replaced by components which are free from defects. Title to replaced products or components is transferred to us.
- The automatically generated original proof of purchase which shows the date of purchase, the type of machine and the serial number, if applicable, is the precondition in order to assert liability or warranty claims. If the original proof of purchase is not presented, we are not able to perform any services.
- Defects resulting from the following circumstances are excluded from liability and warranty claims:
  - Using the product beyond the technical options and proper use, in particular due to overstraining of the machine.
  - Any defects arising by one's own fault due to faulty operations or if the operating manual is disregarded.
  - Inattentive or incorrect handling and use of improper equipment
  - Unauthorized modifications and repairs
  - Insufficient installation and safeguarding of the machine
  - Disregarding the installation requirements and conditions of use
  - atmospheric discharges, overvoltage and lightning strokes as well as chemical influences
- The following items are also not subject to liability or warranty claims:
  - Wearing parts and components which are subject to a standard wear as intended such as e.g. V-belts, ball bearings, illuminants, filters, sealings, etc.
  - Non reproducible software errors
- Any services, which OPTIMUM GmbH or one of its agents performs in order to fulfil any additional warranty are neither an acceptance of the defects nor an acceptance of its obligation to compensate. These services neither delay nor interrupt the warranty period.
- The court of jurisdiction for legal disputes between businessmen is Bamberg.
- If any of the aforementioned agreements is totally or partially inoperative and/or invalid, a provision which nearest approaches the intent of the guarantor and remains within the framework of the limits of liability and warranty which are specified by this contract is deemed agreed.



## 8.4 Storage

### ATTENTION!

**Incorrect and improper storage might result in damage or destruction of electrical and mechanical machine components.**

**Store packed and unpacked parts only under the intended environmental conditions.**

**Follow the instructions and information on the transport box:**



- Fragile goods  
(Goods require careful handling)
- Protect against moisture and humid environment
- Prescribed position of the packing case  
(Marking the top surface - arrows pointing up)
- Maximum stacking height



Example: not stackable - do not stack further packing case on top of the first one.

Consult Optimum Maschinen Germany GmbH if the machine and accessories are stored for more than three months or are stored under different environmental conditions than those specified here .

## 8.5 Dismantling, disassembling, packing and loading

### INFORMATION

Please take care in your interest and in the interest of the environment that all component parts of the machine are only disposed of in the intended and admitted way.

Please note that the electrical devices comprise a variety of reusable materials as well as environmentally hazardous components. Please ensure that these components are disposed of separately and professionally. In case of doubt, please contact your municipal waste management. If appropriate, call on the help of a specialist waste disposal company for the treatment of the material.

Please make sure that electrical components are disposed of professionally and in accordance with the statutory provisions.

The machine contains electrical and electronic components and must not be disposed of as household waste. According to the European directive 2011/65/EU regarding disused electrical and electronic devices and the implementation in national law, disused electrical tools and electrical equipment must be stored separately and recycled in an environmentally friendly manner.

As the equipment operator, you should obtain information regarding the authorized collection or disposal system which applies for your company.

Please make sure that electrical components are disposed of professionally and in accordance with legal regulations. Please only dispose of used batteries via the collection boxes in shops or at municipal waste management companies.





## 8.5.1 Decommissioning

### CAUTION!

Disused machines need to be decommissioned in a professional manner in order to avoid later misuse and endangerment of the environment or persons.

- Disassemble the machine if required into easy-to-handle and reusable assemblies and component parts.
- Dispose of machine components and operating fluids using the intended disposal methods.



## 8.5.2 Dismantling

- Pull the power cord or disassemble the connection cable and disconnect the connection cable.

## 8.5.3 Disassembly

- Drain oil from the speed gear unit.
- Drain oil from the feed gear.
- Disassemble the drive motor.

## 8.5.4 Packing and loading

- Place the machine on a pallet for removal.

## 8.6 Disposal of new device packaging

All used packaging materials and packaging aids from the machine are recyclable and generally need to be supplied to the material reuse.

The packaging wood can be supplied to the disposal or the reuse.

Any packaging components made of cardboard box can be chopped up and supplied to the waste paper collection.

The films are made of polyethylene (PE) and the cushion parts are made of polystyrene (PS). These materials can be reused after reconditioning if they are passed to a collection station or to the appropriate waste management enterprise.

Only forward the packaging materials correctly sorted to allow direct reuse.

## 8.7 Disposal of lubricants and cooling lubricants

### ATTENTION!

Please imperatively make sure to dispose of the used coolant and lubricants in an environmentally compatible manner. Observe the disposal instructions of your municipal waste management companies.



### INFORMATION

Used coolant emulsions and oils should not be mixed since it is only possible to reuse oils without pre-treatment when they have not been mixed.

The disposal instructions for used lubricants are made available by the manufacturer of the lubricants. If necessary, request the product-specific data sheets.





## 8.8 Disposal via municipal collection facilities

Disposal of used electrical and electronic components

(Applicable in the countries of the European Union and other European countries with a separate collecting system for those devices).



The sign on the product or on its packing indicates that the product must not be handled as common household waste, but that it needs to be disposed of at a central collection point for recycling. Your contribution to the correct disposal of this product will protect the environment and the public health. Incorrect disposal constitutes a risk to the environment and public health. Recycling of material will help reduce the consumption of raw materials. For further information about the recycling of this product, please consult your District Office, municipal waste collection station or the shop where you have purchased the product.

## 8.9 Product follow-up

We are required to perform a follow-up service for our products which extends beyond shipment.

We would be grateful if you could send us the following information:

- Modified settings
- Any experiences with the lathe which might be important for other users
- Recurring malfunctions

Hare & Forbes Machineryhouse

Unit 1/2 Windsor Road

Northmead NSW 2152

email [sales@machineryhouse.com.au](mailto:sales@machineryhouse.com.au)

## 8.10 Change information manual

Chapter	Short summary	new version number
parts	multi wedged pulley + double bearings	1.1
2	Correction oil amount feed gear	1.1.1
2	Correction of spindle speed	1.1.2
4.10.4	Calculation for transmission ratio removed	1.1.3
3	Interdepartmental transport	1.1.4
Parts	Additional double channel electric diagram	1.1.5
3.2.1	Load attachment point	1.1.6



## EC - Declaration of Conformity

### Machinery Directive 2006/42/EC Annex II 1.A

**The manufacturer / distributor** Optimum Maschinen Germany GmbH  
Dr.-Robert-Pfleger-Str. 26  
D - 96103 Hallstadt, Germany

hereby declares that the following product

**Product designation:** Hand controlled lathe

**Type designation:** TU3008G

fulfills all the relevant provisions of the directive specified above and the additionally applied directives (in the following) - including the changes which applied at the time of the declaration.

### Description:

Hand controlled lathe without numerical control

### The following other EU Directives have been applied:

EMC Directive 2014/30/EC ; Restriction of the use of certain hazardous substances in electrical and electronic equipment 2015/863/EU

### The following harmonized standards were applied:

EN ISO 23125:2015 - Machine tools - Safety - Turning machines

EN 60204-1:2014 - Safety of machinery - Electrical equipment of machines - Part 1: General requirements

EN 13849-1:2015 - Safety of machinery - Safety related parts of controls - Part 1: General design principles

EN 13849-2:2012 - Safety of machinery - Safety related parts of controls - Part 2: Validation

EN ISO 12100:2013 - Safety of machinery - General principles for design - Risk assessment and risk reduction

Name and address of the person authorized to compile the technical file:

Kilian Stürmer, phone: +49 (0) 951 96555 - 800

Kilian Stürmer (CEO, General Manager)

Hallstadt, 2021-07-14

## 9 Genauigkeitsbericht - Accuracy report

Der ausgefüllte Genauigkeitsbericht liegt der Maschine separat bei. *The completed accuracy report is enclosed separately with the machine.*

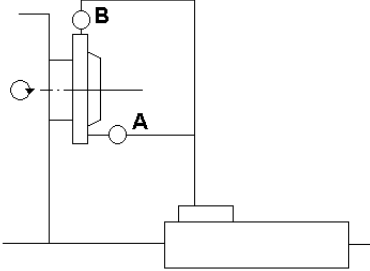
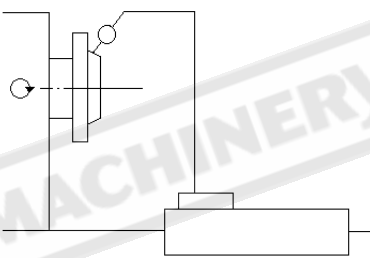
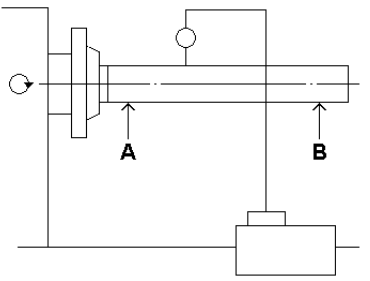
Nr. No.	Testobjekt Object of testing	Zeichnung Drawing	Zulässig max. admissible tolerance [ mm ]	Messwert Measured value [ mm ]
1	Axialruhe und Rundlaufgenauigkeit der Drehspindel  <i>Run-out of spindle and periodical radial slip of spindle</i>		A: 0,009 B: 0,009	A: B:
2	Rundlaufgenauigkeit der Drehspindelaufnahme  <i>Run-out of spindle nose</i>		0,009	
3	Rundlaufgenauigkeit des Innenkegels der Arbeitsspindel  <i>Run-out of internal taper of spindle</i>		A: 0,015 B: 0,03	A: B:

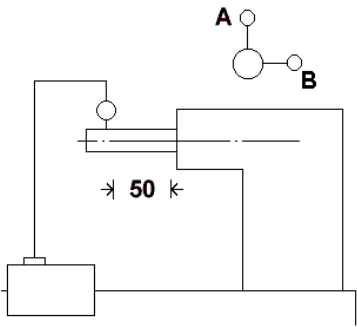
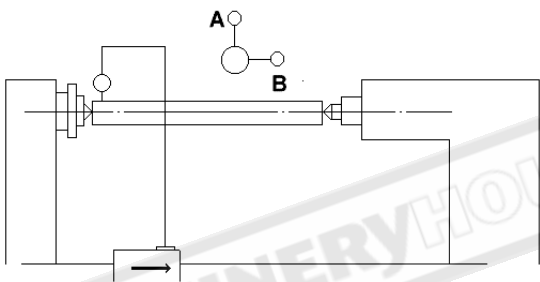
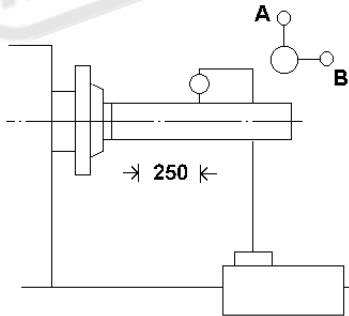
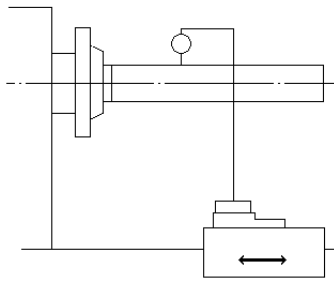

Nr. No.	Testobjekt Object of testing	Zeichnung Drawing	Zulässig max. admissible tolerance [ mm ]	Messwert Measured value [ mm ]
4	<p>Parallelität des Morsekonus der Reitstockpinole A = senkrecht B = waagrecht</p> <p><i>Parallelism of tailstock guides A = in the vertical plane B = in the horizontal plane</i></p>		<p>A: 0,025/50 B: 0,015/50</p>	<p>A: B:</p>
5	<p>Fluchten der beiden Körnerspitzen Drehspindelaufnahme (MK 3) Reitstockaufnahme (MK 2)</p> <p><i>Headstock (MT 3) and tailstock (MT 2) centres for same height above reference plane</i></p>		<p>A: 0,03</p>	<p>A:</p>
6	<p>Parallelität der Arbeitsspindel A = senkrecht B = waagrecht</p> <p><i>Parallelism of spindle axis with carriage movement A = vertical plane B = horizontal plane</i></p>		<p>A: 0,03/250 B: 0,03/250</p>	<p>A: B:</p>
7	<p>Parallelität des Oberschlittens zur Arbeitsspindel und Bettschlittenbewegung</p> <p><i>Parallelism of of top slide with spindle and carriage movement</i></p>		<p>0,04/75</p>	

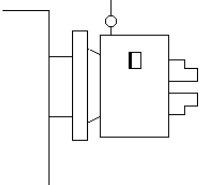
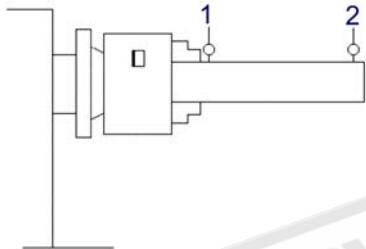
Nr. No.	Testobjekt Object of testing	Zeichnung Drawing	Zulässig max. admissible tolerance [ mm ]	Messwert Measured value [ mm ]
8	Rundlauf Drehfutter  <i>Run-out of yaw chuck</i>		0,04	
9	Rundlauf Drehfutter Prüfdorn A: Ø 20mm B: Ø 30mm  <i>Run-out of yaw chuck</i> <i>Object of testing</i> A: Ø 20mm B: Ø 30mm		A) Ø 20mm 1: 0,04  2: 0,08/100  B) Ø 30mm 1: 0,04  2: 0,08/100	A) 1:  2:  B) 1:  2:

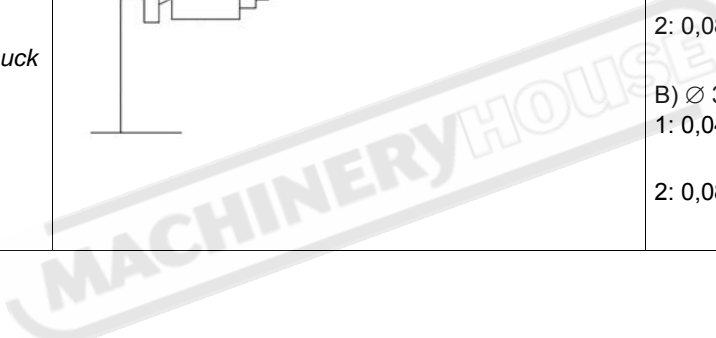



## Index

### A

Abnahmeprotokoll .....	112
Adjusting the feed rate .....	31

### C

Center of Gravity .....	21
Change gears .....	31
Changing	
feed rate .....	30
Changing of change gears .....	31
Changing the speed	
speed range .....	30
Clamping force-speed diagram .....	63
Cleaning .....	23
Commissioning .....	23
Control elements .....	28
Cooling lubricant .....	58
Copyright .....	106
Customer service .....	74
Customer service technician .....	74
Cutting speed .....	41
Cutting speed table .....	41

### O

Obligations	
User .....	10

### P

Protective	
equipment .....	14
Protective cover	
feed rod .....	11
headstock .....	12
lathe chuck .....	13
lead screw .....	11
Protokoll .....	112

### Q

Qualification of personnel	
Safety .....	10

### R

Restoring	
readiness for operation .....	29

### S

Safety .....	6
Lathe chuck .....	61
Selector switch .....	30
Service Hotline .....	75
Specialist dealer .....	74
Switching on .....	28
Switching on the machine .....	28

### T

Tailstock .....	54
cross offset .....	55
Target group	
private users .....	10
Thread cutting .....	57
Thread types .....	46
Tightening torques	
chuck .....	66
Turning short tapers .....	56
Turning tapers .....	37
Type plates .....	6

### U

Using	
lifting equipment .....	15

### W

Warming up the machine .....	24
------------------------------	----



MACHINERYHOUSE